

POD PHONE SMALL

POD PHONE SMALL is a telephone booth that improves privacy when taking phone calls in open spaces and office environments.



TECHNICAL INFORMATION

AIR FLOW	Fully automated ventilation controlled by motion sensor that is adjustable up to 99 minutes. Airflow rate of 22 l/s when occupied.
LIGHTING	Fully automated lights controlled by motion sensor that is adjustable up to 99 minutes. LED light set on the ceiling. Lumen 871.
WHEELS	Installation wheels included.
ENERGY CONSUMPTION	Total capacity 18,95 W. Fans capacity 4,45 W. Lights capacity 14,5 W. Max load 8 A.
SOCKET	One electrical power socket on the table.
POWER CONNECTION	Electricity connection from the ceiling or floor. The length of the power cord is 3 m.

MEASUREMENTS

EXTERNAL DIMENSIONS	W1000 x D1200 x H2220 mm
INNER DIMENSIONS	W800 x D800 x H2040 mm
DOOR	8 x 21
PACKAGE DIMENSIONS	W800 x D2400 x H1500 mm
WEIGHT	400 kg 333 kg/m ²

MEASUREMENTS

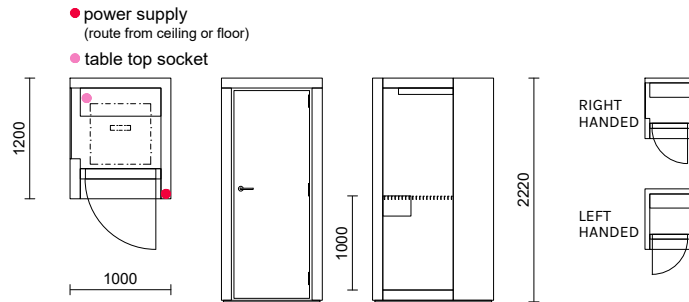

MATERIAL DESCRIPTION

EXTERIOR	Melamine or veneered frame.
INTERIOR	Acoustic panel on the ceiling. Walls x 2 and floor coated with carpet.
DOOR	Painted MDF door. Melamine door side panels. Door handle with satin finished stainless steel.
WINDOW	Laminated acoustic safety glass window 10 mm. Glass window includes the INTO stripe window taping.
TABLE	Fixed MDF table with water-based paint.

ADD-ON FEATURES

POD PANEL

POD PANEL is an acoustic-friendly add-on piece for POD rooms. It can be used as a surface to attach notes, plans, and other sketches. Panels attaches easily to the POD exterior and softens the surrounding sound environment.

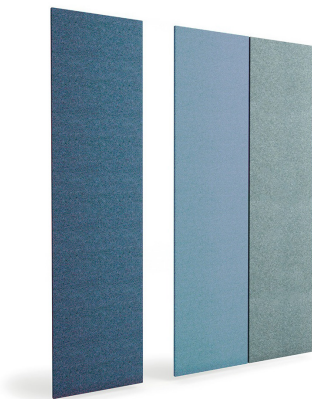

OTHER AVAILABLE ADD-ON FEATURES

- Height adjustable stool
- Clothing hook
- Electronical lock system
- Booking system
- Smart glass
- Screen holder
- USB charger
- Extra power sockets
- AV systems (web camera, microphone)





All our materials comply with M1 emission classification or similar.

SURFACE FINISHES FOR POD ROOMS

STANDARD PRICE, CATEGORY 1

Melamine color options



White



Dark grey

PRICE CATEGORY 2

Veneer material options



Pine



American oak



Black oak



SURFACE FINISHES FOR DOOR & DOOR SIDE PANELS

STANDARD PRICE, CATEGORY 1

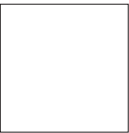

White

PRICE CATEGORY 2



Clear glass 10 mm

comes with white door panels

PRICE CATEGORY 3



American oak

CARPETS FOR POD ROOMS: EX-DONO QUARTET FROM FLETCO | STANDARD PRICE, CATEGORY 1

Composition: Polyester non woven
 Static electrical propensity: Antistatic
 Impact sound reduction: 25 dB
 Classification for use: Commercial / heavy use
 Fire resistant: Yes

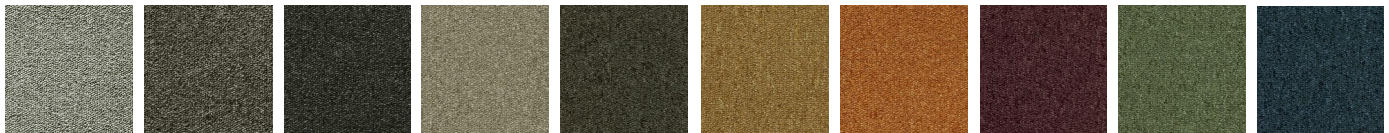

393300 393340 393350 393120 393260 393450 393550 393660 393750 393850

Ask for more colors: sales@intoconcept.com

CEILING ACOUSTIC PANEL FABRIC: SOUL FROM GABRIEL | STANDARD PRICE, CATEGORY 1

Composition: 100% wool
 Lightfastness: 5-7
 Rubbing fastness: 4/wet, 4-5/dry
 Sustainability: Complies with STANDARD 100 by OEKO-TEX
 Meet Möbelfakta requirements
 Cleaning: regular vacuum cleaning
 Fire resistant: Yes (S 476 Part 7, class 1 ÖNORM B 3825-B1-3800-Q1 UK)



66104 67039 68131 64086 62059 61196 60182 68128 61199 60099

Ask for more colors: sales@intoconcept.com

POD PHONE

POD PHONE is a spacious phone booth that improves privacy when taking phone calls in open spaces and office environments.



TECHNICAL INFORMATION

AIR FLOW	Fully automated ventilation controlled by motion sensor that is adjustable up to 99 minutes. Airflow rate of 22 l/s when occupied.
LIGHTING	Fully automated lights controlled by motion sensor that is adjustable up to 99 minutes. LED light set on the ceiling. Lumen 871.
WHEELS	Installation wheels included.
ENERGY CONSUMPTION	Total capacity 18,95 W. Fans capacity 4,45 W. Lights capacity 14,5 W. Max load 8 A.
SOCKET	One power socket on the table.
POWER CONNECTION	Electricity connection from the ceiling or floor. The length of the power cord is 3 m.

MEASUREMENTS

EXTERNAL DIMENSIONS	W1000 x D1500 x H2220 mm
INNER DIMENSIONS	W800 x D1100 x H2040 mm
DOOR	8 x 21
PACKAGE DIMENSIONS	W800 x D2400 x H1500 mm
WEIGHT	460 kg 307 kg/m ²

MEASUREMENTS

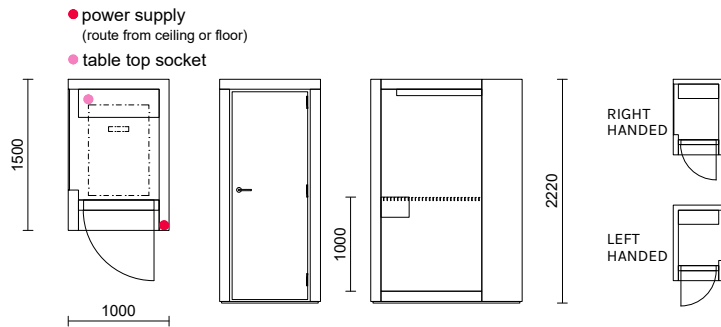

MATERIAL DESCRIPTION

EXTERIOR	Melamine or veneered frame.
INTERIOR	Acoustic panel on the ceiling. Walls x 2 and floor coated with carpet.
DOOR	Painted MDF door. Melamine door side panels. Door handle with satin finished stainless steel.
WINDOW	Laminated acoustic safety glass window 10 mm. Glass window includes the INTO stripe window taping.
TABLE	Fixed MDF table with water-based paint.

ADD-ON FEATURES

POD PANEL

POD PANEL is an acoustic-friendly add-on piece for POD rooms. It can be used as a surface to attach notes, plans, and other sketches. Panels attaches easily to the POD exterior and softens the surrounding sound environment.



OTHER AVAILABLE ADD-ON FEATURES

- Height adjustable stool
- Clothing hook
- Electronical lock system
- Booking system
- Smart glass
- Screen holder
- USB charger
- Extra power sockets
- AV systems (web camera, microphone)





All our materials comply with M1 emission classification or similar.

SURFACE FINISHES FOR POD ROOMS

STANDARD PRICE, CATEGORY 1

Melamine color options



White Dark grey

PRICE CATEGORY 2

Veneer material options

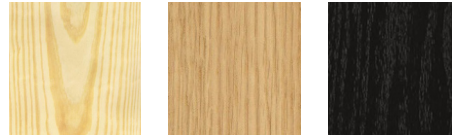

Pine American oak Black oak



The mark of responsible forestry

SURFACE FINISHES FOR DOOR & DOOR SIDE PANELS

STANDARD PRICE, CATEGORY 1



White

PRICE CATEGORY 2



Clear glass 10 mm

comes with white door panels

PRICE CATEGORY 3

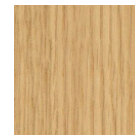

American oak

CARPETS FOR POD ROOMS: EX-DONO QUARTET FROM FLETCO | STANDARD PRICE, CATEGORY 1

Composition: Polyester non woven
 Static electrical propensity: Antistatic
 Impact sound reduction: 25 dB
 Classification for use: Commercial / heavy use
 Fire resistant: Yes



393300 393340 393350 393120 393260 393450 393550 393660 393750 393850

Ask for more colors: sales@intoconcept.com

CEILING ACOUSTIC PANEL FABRIC: SOUL FROM GABRIEL | STANDARD PRICE, CATEGORY 1

Composition: 100% wool
 Lightfastness: 5-7
 Rubbing fastness: 4/wet, 4-5/dry
 Sustainability: Complies with STANDARD 100 by OEKO-TEX
 Meet Möbelfakta requirements
 Cleaning: regular vacuum cleaning
 Fire resistant: Yes (S 476 Part 7, class 1 ÖNORM B 3825-B1-3800-Q1 UK)



66104 67039 68131 64086 62059 61196 60182 68128 61199 60099

Ask for more colors: sales@intoconcept.com

POD 1

POD 1 is a quiet workspace for 1-2 people, designed for tasks that require focus and for private phone calls.



TECHNICAL INFORMATION

AIR FLOW	Fully automated ventilation controlled by motion sensor that is adjustable up to 99 minutes. Switch for ventilation. Airflow rate of 22 l/s when occupied.
LIGHTING	Fully automated lights controlled by motion sensor that is adjustable up to 99 minutes. Switch for lights. 2 x LED light set on the ceiling. A window lamp. Lumen 1742.
WHEELS	Installation wheels included.
ENERGY CONSUMPTION	Total capacity 40,45 W. Fans capacity 4,45 W. Lights capacity 36 W. Max load 8 A.
SOCKET	3 x power sockets + 1 x data outlet included.
POWER CONNECTION	POD electricity connection from the ceiling or floor. The length of the power cord is 3 m.

MEASUREMENTS

EXTERNAL DIMENSIONS	W1700 x D1700 x H2220 mm
DOOR	9 x 21
INNER DIMENSIONS	W1500 x D1300 x H2040 mm
PACKAGE DIMENSIONS	W1200 x D2400 x H1500 mm
WEIGHT	690 kg 239kg/m ²

MEASUREMENTS

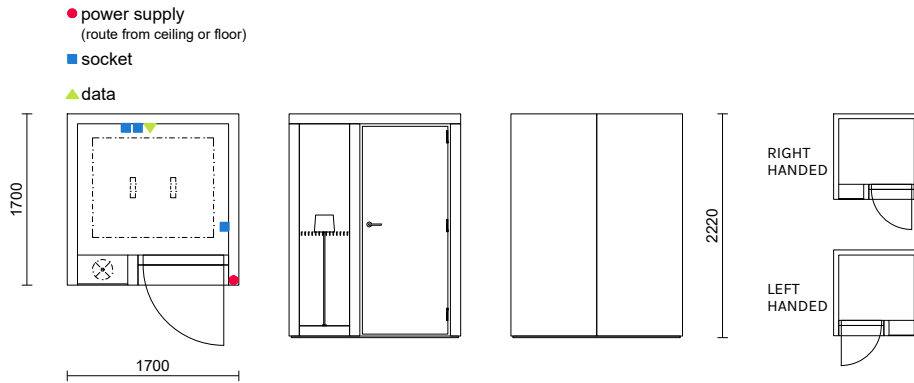

MATERIAL DESCRIPTION

EXTERIOR	Melamine or veneered frame.
INTERIOR	Acoustic panel on the ceiling. Back wall and floor coated with carpet.
DOOR	Painted MDF door. Melamine door side panels. Door handle with satin finished stainless steel.
WINDOW	Laminated acoustic safety glass window 10 mm. Glass window includes the INTO stripe window taping.



ADD-ON FEATURES

POD PANEL

POD PANEL is an acoustic-friendly add-on piece for POD rooms. It can be used as a surface to attach notes, plans, and other sketches. Panels attaches easily to the POD exterior and softens the surrounding sound environment.



ACCESSIBILITY SET

Wheelchair ramp.
Reservation for automatic door.
Automatic door closer.
Hydraulic door closer.
Kick-plates for the door and/or walls.
Vertical and/or horizontal bar handles.

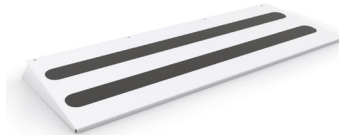

FURNITURE SET

Furnish the POD room with INTO sofas and tables.
For example:
2 x POINT LOW M 700 mm
TOP S 400 x 600 x H680-1080 mm

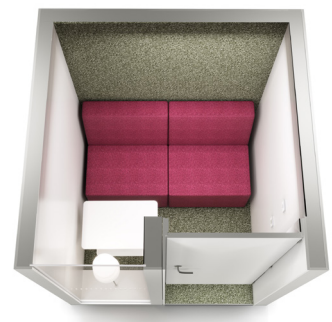

OTHER AVAILABLE ADD-ON FEATURES

Air cooling device
Clothing hook
Electronical lock system
Booking system
Smart glass
USB charger
Extra power sockets
AV systems (web camera, microphone)



All our materials comply with M1 emission classification or similar.

SURFACE FINISHES FOR POD ROOMS

STANDARD PRICE, CATEGORY 1

Melamine color options

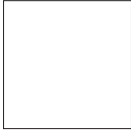

White



Dark grey

PRICE CATEGORY 2

Veneer material options



Pine



American oak



Black oak



SURFACE FINISHES FOR DOOR & DOOR SIDE PANELS

STANDARD PRICE, CATEGORY 1

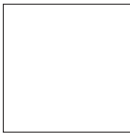

White

PRICE CATEGORY 2



Clear glass 10 mm

comes with white door panels

PRICE CATEGORY 3

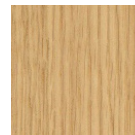

American oak

CARPETS FOR POD ROOMS: EX-DONO QUARTET FROM FLETCO | STANDARD PRICE, CATEGORY 1

Composition: Polyester non woven
 Static electrical propensity: Antistatic
 Impact sound reduction: 25 dB
 Classification for use: Commercial / heavy use
 Fire resistant: Yes



393300 393340 393350 393120 393260 393450 393550 393660 393750 393850

Ask for more colors: sales@intoconcept.com

CEILING ACOUSTIC PANEL FABRIC: SOUL FROM GABRIEL | STANDARD PRICE, CATEGORY 1

Composition: 100% wool
 Lightfastness: 5-7
 Rubbing fastness: 4/wet, 4-5/dry
 Sustainability: Complies with STANDARD 100 by OEKO-TEX
 Meet Möbelfakta requirements
 Cleaning: regular vacuum cleaning
 Fire resistant: Yes (S 476 Part 7, class 1 ÖNORM B 3825-B1-3800-Q1 UK)



66104 67039 68131 64086 62059 61196 60182 68128 61199 60099

Ask for more colors: sales@intoconcept.com

POD 2

The POD 2 small meeting room is ideal for 2-4 people for spontaneous but confidential meetings and as an adaptable workspace.



TECHNICAL INFORMATION

AIR FLOW	Fully automated ventilation controlled by motion sensor that is adjustable up to 99 minutes. Switch for ventilation. Airflow rate of 44 l/s when occupied.
LIGHTING	Fully automated lights controlled by motion sensor that is adjustable up to 99 minutes. Switch for lights. 2 x LED light set on the ceiling. A window lamp. Lumen 1742.
WHEELS	Installation wheels included.
ENERGY CONSUMPTION	Total capacity 44,9 W. Fans capacity 8,9 W. Lights capacity 36 W. Max load 8 A.
SOCKET	3 x power sockets + 2 x data outlets included.
POWER CONNECTION	POD electricity connection from the ceiling or floor. The length of the power cord is 3 m.

MEASUREMENTS

EXTERNAL DIMENSIONS	W2500 x D1700 x H2220 mm
DOOR	9 x 21
INNER DIMENSIONS	W2300 x D1300 x H2040 mm
PACKAGE DIMENSIONS	W1200 x D2520x H1500 mm
WEIGHT	910 kg 214 kg/m ²

MEASUREMENTS

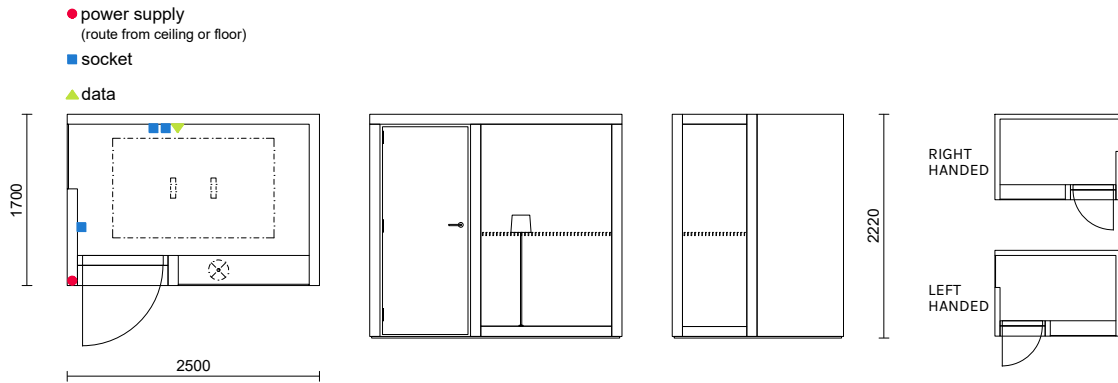

MATERIAL DESCRIPTION

EXTERIOR	Melamine or veneered frame.
INTERIOR	Acoustic panel on the ceiling. Back wall and floor coated with carpet.
DOOR	Painted MDF door. Melamine door side panels. Door handle with satin finished stainless steel.
WINDOW	Laminated acoustic safety glass window 10 mm. Glass window includes the INTO stripe window taping.



ADD-ON FEATURES

POD PANEL

POD PANEL is an acoustic-friendly add-on piece for POD rooms. It can be used as a surface to attach notes, plans, and other sketches. Panels attaches easily to the POD exterior and softens the surrounding sound environment.



ACCESSIBILITY SET

Wheelchair ramp.
Reservation for automatic door.
Automatic door closer.
Hydraulic door closer.
Kick-plates for the door and/or walls.
Vertical and/or horizontal bar handles.



FURNITURE SET

Furnish the POD room with INTO sofas and tables.
For example:
1 x POINT LOW M 700 mm
2 x POINT LOW S 500 mm
TOP L 600 x 800 x H680-1080 mm



OTHER AVAILABLE ADD-ON FEATURES

Air cooling device
Clothing hook
Electronical lock system
Booking system
Smart glass
USB charger
Extra power sockets
AV systems (web camera, microphone)
Automatic fire extinguisher system



All our materials comply with M1 emission classification or similar.

SURFACE FINISHES FOR POD ROOMS

STANDARD PRICE, CATEGORY 1

Melamine color options

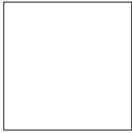

White



Dark grey

PRICE CATEGORY 2

Veneer material options



Pine

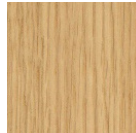

American oak



Black oak



SURFACE FINISHES FOR DOOR & DOOR SIDE PANELS

STANDARD PRICE, CATEGORY 1



White



Clear glass 10 mm

comes with white door panels

PRICE CATEGORY 3



American oak

CARPETS FOR POD ROOMS: EX-DONO QUARTET FROM FLETCO | STANDARD PRICE, CATEGORY 1

Composition: Polyester non woven
 Static electrical propensity: Antistatic
 Impact sound reduction: 25 dB
 Classification for use: Commercial / heavy use
 Fire resistant: Yes

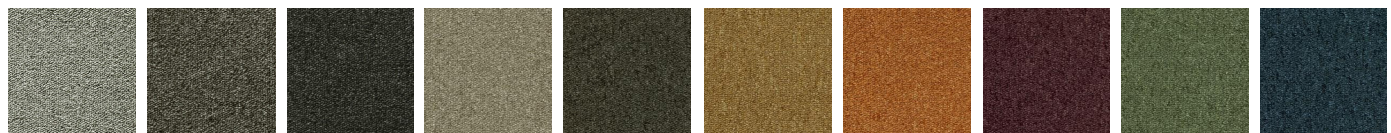

393300 393340 393350 393120 393260 393450 393550 393660 393750 393850

Ask for more colors: sales@intoconcept.com

CEILING ACOUSTIC PANEL FABRIC: SOUL FROM GABRIEL | STANDARD PRICE, CATEGORY 1

Composition: 100% wool
 Lightfastness: 5-7
 Rubbing fastness: 4/wet, 4-5/dry
 Sustainability: Complies with STANDARD 100 by OEKO-TEX
 Meet Möbelfakta requirements
 Cleaning: regular vacuum cleaning
 Fire resistant: Yes (S 476 Part 7, class 1 ÖNORM B 3825-B1-3800-Q1 UK)



66104 67039 68131 64086 62059 61196 60182 68128 61199 60099

Ask for more colors: sales@intoconcept.com

POD 3

POD 3 is a versatile workspace ideal for 1-3 people, offering a compact setting for focused work or easily transforming into a small meeting room for collaborative meetings.



TECHNICAL INFORMATION

AIR FLOW	Fully automated ventilation controlled by motion sensor that is adjustable up to 99 minutes. Switch for ventilation. Airflow rate of 44 l/s when occupied.
LIGHTING	Fully automated lights controlled by motion sensor that is adjustable up to 99 minutes. Switch for lights. 4 x LED light set on the ceiling. A window lamp. Lumen 3484.
WHEELS	Installation wheels included.
ENERGY CONSUMPTION	Total capacity 73,9 W. Fans capacity 8,9 W. Lights capacity 65 W. Max load 8 A.
SOCKET	3 x power sockets + 2 x data outlets included.
POWER CONNECTION	POD electricity connection from the ceiling or floor. The length of the power cord is 3 m.

MEASUREMENTS

EXTERNAL DIMENSIONS	W1700 x D3400 x H2220 mm
DOOR	9 x 21
INNER DIMENSIONS	W1500 x D3000 x H2040 mm
PACKAGE DIMENSIONS	2 x pallet: W1200 x D2500 x H1400 mm and W1200 x D2500x H1400 mm
WEIGHT	1150 kg 198 kg/m ²

MEASUREMENTS

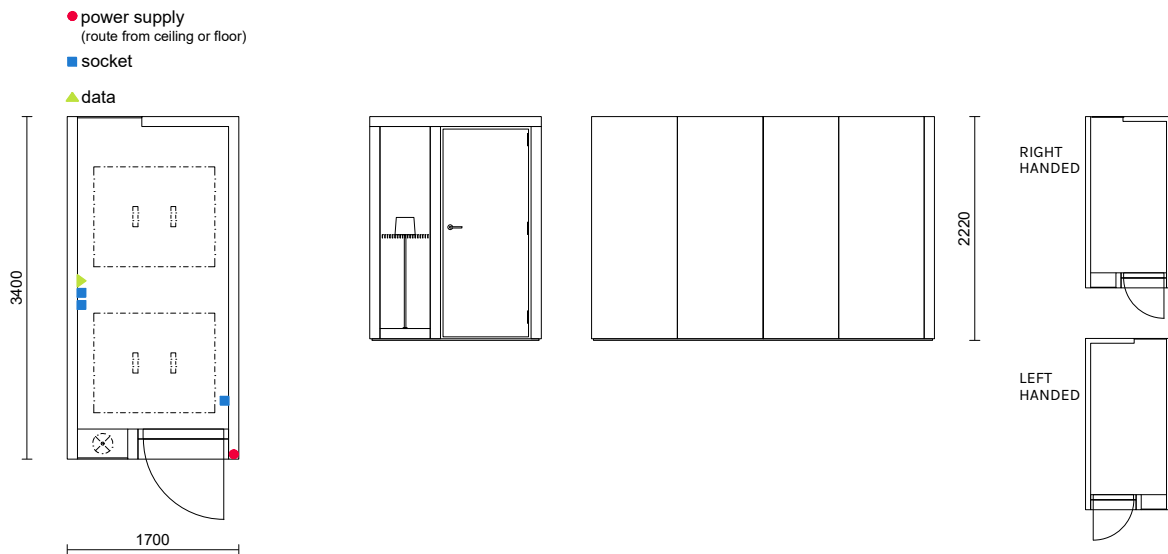

MATERIAL DESCRIPTION

EXTERIOR	Melamine or veneered frame.
INTERIOR	Acoustic panel on the ceiling. One wall and floor coated with carpet.
DOOR	Painted MDF door. Melamine door side panels. Door handle with satin finished stainless steel.
WINDOW	Laminated acoustic safety glass window 10 mm. Glass window includes the INTO stripe window taping.



ADD-ON FEATURES

DISPLAY BOX

DISPLAY BOX is a screen stand for the POD meeting rooms that hides the cables and the remote control. Suitable for a maximum 42" screen.



POD PANEL

POD PANEL is an acoustic-friendly add-on piece for POD rooms. It can be used as a surface to attach notes, plans, and other sketches. Panels attaches easily to the POD exterior and softens the surrounding sound environment.



ACCESSIBILITY SET

- Wheelchair ramp.
- Reservation for automatic door.
- Automatic door closer.
- Hydraulic door closer.
- Kick-plates for the door and/or walls.
- Vertical and/or horizontal bar handles.



FURNITURE SET

Furnish the POD room with INTO tables and height-adjustable stools.
For example:
2 x TOP WORK 1000 x 500 x H680-1080 mm
2 x height adjustable balancing stool



OTHER AVAILABLE ADD-ON FEATURES

- Air cooling device
- Clothing hook
- Electronical lock system
- Booking system
- Smart glass
- USB charger
- Extra power sockets
- AV systems (web camera, microphone)
- Automatic fire extinguisher system



All our materials comply with M1 emission classification or similar.

SURFACE FINISHES FOR POD ROOMS

STANDARD PRICE, CATEGORY 1

Melamine color options

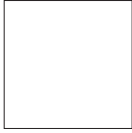

White



Dark grey

PRICE CATEGORY 2

Veneer material options



Pine

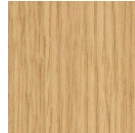

American oak



Black oak



SURFACE FINISHES FOR DOOR & DOOR SIDE PANELS

STANDARD PRICE, CATEGORY 1



White

PRICE CATEGORY 2



Clear glass 10 mm

comes with white door panels

PRICE CATEGORY 3



American oak

CARPETS FOR POD ROOMS: EX-DONO QUARTET FROM FLETCO | STANDARD PRICE, CATEGORY 1

Composition: Polyester non woven
 Static electrical propensity: Antistatic
 Impact sound reduction: 25 dB
 Classification for use: Commercial / heavy use
 Fire resistant: Yes



393300 393340 393350 393120 393260 393450 393550 393660 393750 393850

Ask for more colors: sales@intoconcept.com

CEILING ACOUSTIC PANEL FABRIC: SOUL FROM GABRIEL | STANDARD PRICE, CATEGORY 1

Composition: 100% wool
 Lightfastness: 5-7
 Rubbing fastness: 4/wet, 4-5/dry
 Sustainability: Complies with STANDARD 100 by OEKO-TEX
 Meet Möbelfakta requirements
 Cleaning: regular vacuum cleaning
 Fire resistant: Yes (S 476 Part 7, class 1 ÖNORM B 3825-B1-3800-Q1 UK)



66104 67039 68131 64086 62059 61196 60182 68128 61199 60099

Ask for more colors: sales@intoconcept.com

POD 4

POD 4 meeting rooms are suitable for 4-8 people and perfect for private or confidential meetings as well as adaptable work spaces.



TECHNICAL INFORMATION

AIR FLOW	Fully automated ventilation controlled by motion sensor that is adjustable up to 99 minutes. Switch for ventilation. Airflow rate of 88 l/s when occupied.
LIGHTING	Fully automated lights controlled by motion sensor that is adjustable up to 99 minutes. Switch for lights. 4 x LED light set on the ceiling. 1 window lamp. Lumen 3484.
WHEELS	Installation wheels included.
ENERGY CONSUMPTION	Total capacity 82,8 W. Fans capacity 17,8 W. Lights capacity 65 W. Max load 8 A.
SOCKET	4 x power sockets + 2 x data outlets included.
POWER CONNECTION	POD electricity connection from the ceiling or floor. The length of the power cord is 3 m.

MEASUREMENTS

EXTERNAL DIMENSIONS	W3400 x D2500 x H2220 mm
DOOR	9 x 21
INNER DIMENSIONS	W3200 x D2100 x H2040 mm
PACKAGE DIMENSIONS	2 x pallet: W1200 x D2520 x H1500 and W1200 x D2400 x H1500
WEIGHT	1450 kg 171 kg/m ²

MEASUREMENTS

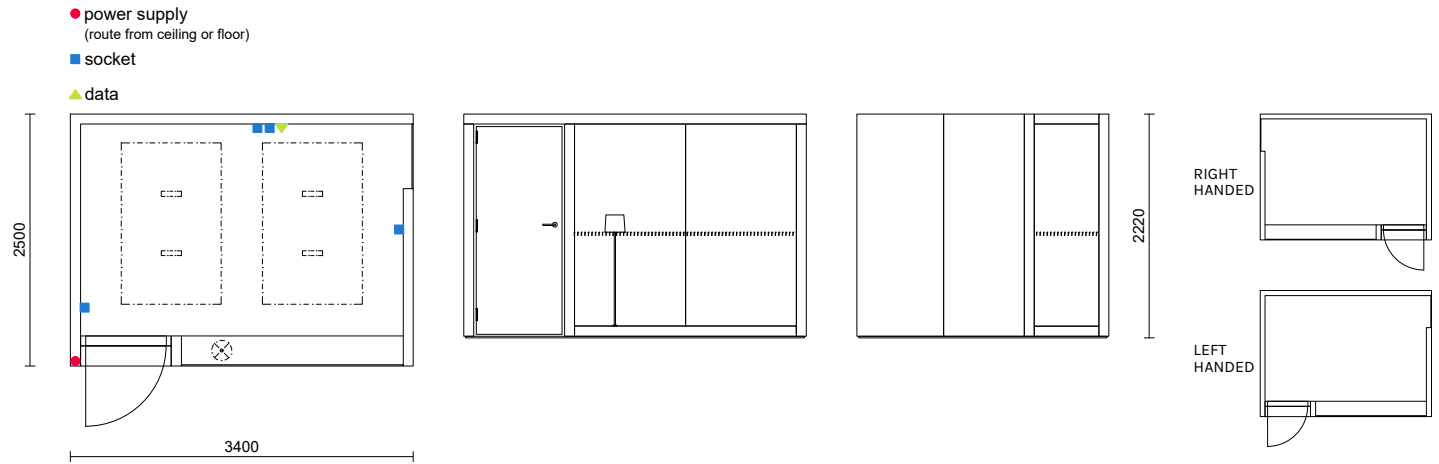

MATERIAL DESCRIPTION

EXTERIOR	Melamine or veneered frame.
INTERIOR	Acoustic panels on the ceiling. Back wall and floor coated with carpet.
DOOR	Painted MDF door. Melamine door side panels. Door handle with satin finished stainless steel.
WINDOW	Laminated acoustic safety glass window 10 mm. Glass window includes the INTO stripe window taping.



ADD-ON FEATURES

DISPLAY BOX

DISPLAY BOX is a screen stand for the POD meeting rooms that hides the cables and the remote control. Suitable for a maximum 42" screen.



POD PANEL

POD PANEL is an acoustic-friendly add-on piece for POD rooms. It can be used as a surface to attach notes, plans, and other sketches. Panels attaches easily to the POD exterior and softens the surrounding sound environment.



ACCESSIBILITY SET

- Wheelchair ramp.
- Reservation for automatic door.
- Automatic door closer.
- Hydraulic door closer.
- Kick-plates for the door and/or walls.
- Vertical and/or horizontal bar handles.



FURNITURE SET

- Furnish the POD room with INTO sofas and tables.
- For example;
- 4 x POINT LOW M 700 mm
- 1 x POINT LOW CORNER
- 2 x TOP CURVE L H720 mm
- 1 x DISPLAY BOX



OTHER ADD-ON FEATURES

- Air cooling device
- Clothing hook
- Electronical lock system
- Booking system
- Smart glass
- USB charger
- Extra power sockets
- AV systems (web camera, microphone)
- Automatic fire extinguisher system



All our materials comply with M1 emission classification or similar.

SURFACE FINISHES FOR POD ROOMS

STANDARD PRICE, CATEGORY 1

Melamine color options

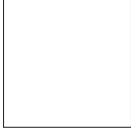

White



Dark grey

PRICE CATEGORY 2

Veneer material options



Pine

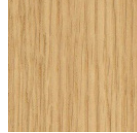

American oak



Black oak



SURFACE FINISHES FOR DOOR & DOOR SIDE PANELS

STANDARD PRICE, CATEGORY 1



White

PRICE CATEGORY 2



Clear glass 10 mm

comes with white door panels

PRICE CATEGORY 3



American oak

CARPETS FOR POD ROOMS: EX-DONO QUARTET FROM FLETCO | STANDARD PRICE, CATEGORY 1

Composition: Polyester non woven
 Static electrical propensity: Antistatic
 Impact sound reduction: 25 dB
 Classification for use: Commercial / heavy use
 Fire resistant: Yes



393300 393340 393350 393120 393260 393450 393550 393660 393750 393850

Ask for more colors: sales@intoconcept.com

CEILING ACOUSTIC PANEL FABRIC: SOUL FROM GABRIEL | STANDARD PRICE, CATEGORY 1

Composition: 100% wool
 Lightfastness: 5-7
 Rubbing fastness: 4/wet, 4-5/dry
 Sustainability: Complies with STANDARD 100 by OEKO-TEX
 Meet Möbelfakta requirements
 Cleaning: regular vacuum cleaning
 Fire resistant: Yes (S 476 Part 7, class 1 ÖNORM B 3825-B1-3800-Q1 UK)



66104 67039 68131 64086 62059 61196 60182 68128 61199 60099

Ask for more colors: sales@intoconcept.com

POD MAX

POD MAX is a meeting room designed for 8-10 people, providing a comfortable space for bigger group meetings.



TECHNICAL INFORMATION

AIR FLOW	Fully automated ventilation controlled by motion sensor that is adjustable up to 99 minutes. Switch for ventilation. Airflow rate of 88 l/s when occupied.
LIGHTING	Fully automated lights controlled by motion sensor that is adjustable up to 99 minutes. Switch for lights. 8 x LED light set on the ceiling. 1 window lamp. Lumen 6968.
WHEELS	Installation wheels included.
ENERGY CONSUMPTION	Total capacity 141 W. Fans capacity 17,8 W. Lights capacity 123 W. Max load 8 A.
SOCKET	6 x power sockets + 4 x data outlets included.
POWER CONNECTION	POD electricity connection from the ceiling or floor. The length of the power cord is 3 m.

MEASUREMENTS

EXTERNAL DIMENSIONS	W3400 x D5000 x H2220 mm
DOOR	9 x 21
INNER DIMENSIONS	W3000 x D4800 x H2040 mm
PACKAGE DIMENSIONS	2 x pallet: W1200 x D2500 x H1400 and W1200 x D2500 x H1400
WEIGHT	2500 kg 147 kg/m ²

MEASUREMENTS

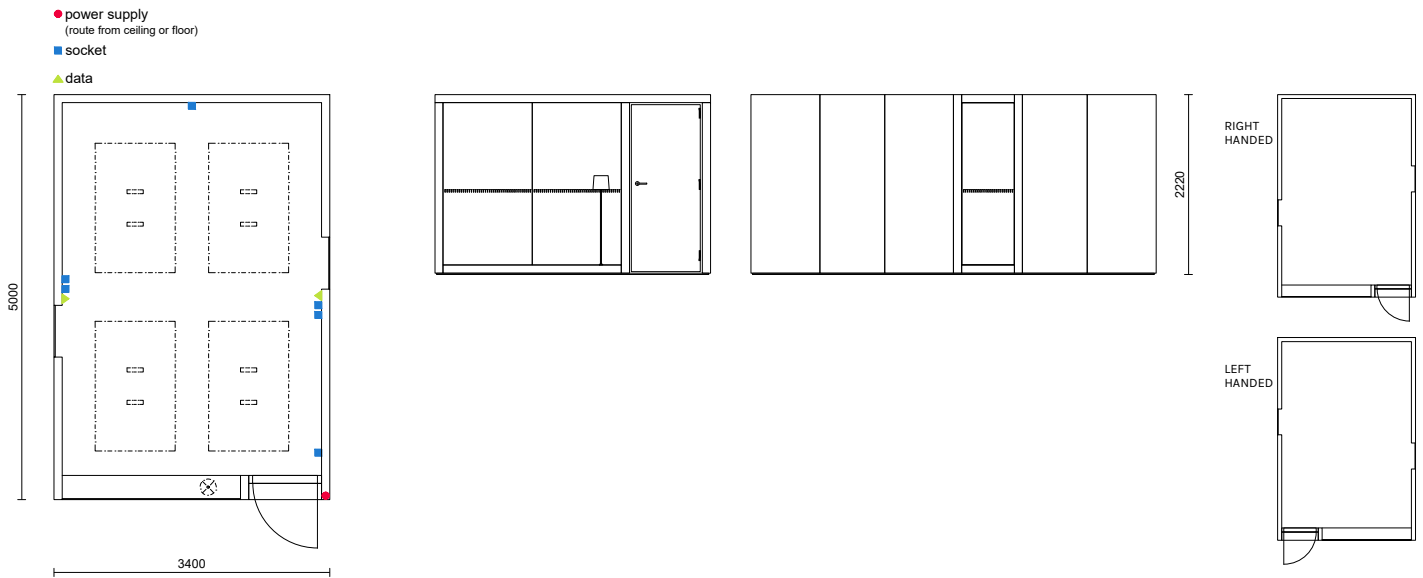

MATERIAL DESCRIPTION

EXTERIOR

Melamine or veneered frame.

INTERIOR

Acoustic panels on the ceiling.
 Back wall and floor coated with carpet.

DOOR

Painted MDF door. Melamine door side panels.
 Door handle with satin finished stainless steel.

WINDOW

Laminated acoustic safety glass window 10 mm.
 Glass window includes the INTO stripe window taping.



ADD-ON FEATURES

DISPLAY BOX

DISPLAY BOX is a screen stand for the POD meeting rooms that hides the cables and the remote control. Suitable for a maximum 42" screen.



POD PANEL

POD PANEL is an acoustic-friendly add-on piece for POD rooms. It can be used as a surface to attach notes, plans, and other sketches. Panels attaches easily to the POD exterior and softens the surrounding sound environment.



ACCESSIBILITY SET

- Wheelchair ramp.
- Reservation for automatic door.
- Automatic door closer.
- Hydraulic door closer.
- Kick-plates for the door and/or walls.
- Vertical and/or horizontal bar handles.



FURNITURE SET

Furnish the POD MAX room with 2 x conference tables and 8 x conference chairs.

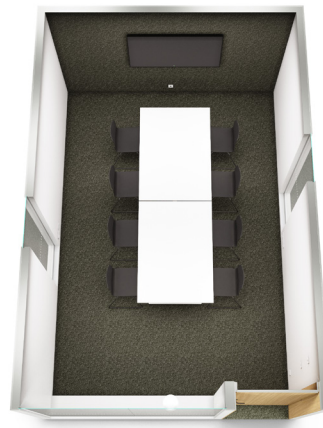

OTHER ADD-ON FEATURES

- Air cooling device
- Clothing hook
- Electronical lock system
- Booking system
- Smart glass
- USB charger
- Extra power sockets
- AV systems (web camera, microphone)
- Automatic fire extinguisher system



All our materials comply with M1 emission classification or similar.

SURFACE FINISHES FOR POD ROOMS

STANDARD PRICE, CATEGORY 1

Melamine color options



White Dark grey

PRICE CATEGORY 2

Veneer material options



Pine American oak Black oak



SURFACE FINISHES FOR DOOR & DOOR SIDE PANELS

STANDARD PRICE, CATEGORY 1



White

PRICE CATEGORY 2



Clear glass 10 mm

comes with white door panels

PRICE CATEGORY 3



American oak

CARPETS FOR POD ROOMS: EX-DONO QUARTET FROM FLETCO | STANDARD PRICE, CATEGORY 1

Composition: Polyester non woven
 Static electrical propensity: Antistatic
 Impact sound reduction: 25 dB
 Classification for use: Commercial / heavy use
 Fire resistant: Yes



393300 393340 393350 393120 393260 393450 393550 393660 393750 393850

Ask for more colors: sales@intoconcept.com

CEILING ACOUSTIC PANEL FABRIC: SOUL FROM GABRIEL | STANDARD PRICE, CATEGORY 1

Composition: 100% wool
 Lightfastness: 5-7
 Rubbing fastness: 4/wet, 4-5/dry
 Sustainability: Complies with STANDARD 100 by OEKO-TEX
 Meet Möbelfakta requirements
 Cleaning: regular vacuum cleaning
 Fire resistant: Yes (S 476 Part 7, class 1 ÖNORM B 3825-B1-3800-Q1 UK)



66104 67039 68131 64086 62059 61196 60182 68128 61199 60099

Ask for more colors: sales@intoconcept.com

POD ROLL

POD ROLL is a workspace for 2-4 people, ideal for spontaneous meetings, independent work, or use as a break area.



TECHNICAL INFORMATION

Solution includes POINT sofas, table, ceiling lamp, screen holder, power sockets, and wheels.

LIGHTING	Fully automated lights with electronic motion sensor. Switch for lights. Ceiling light. Lumen 2100.
WHEELS	Wheels under the POD ROLL make it easy to turn and move around if needed.
ENERGY CONSUMPTION	Total capacity 14 W. Lights capacity 14 W. Max load 8 A.
SOCKET	One power socket on the tabletop + 3 under the table.
POWER CONNECTION	POD electricity connection from the ceiling or floor. The length of the power cord is 3 m.
SCREEN HOLDER	VESA mounting, does not include screen, max screen size 28".

MEASUREMENTS

EXTERNAL DIMENSIONS	W2300 x D1700 x H2230 mm
INNER DIMENSIONS	W2000 x D1640 x H1980 mm
TABLE	700 x 1100 x H730 mm
PACKAGE DIMENSIONS	2 x pallet: W1000 x D2500 x H1500 mm and W850 x D1700 x H2000 mm
WEIGHT	700 kg 179 kg/m ²

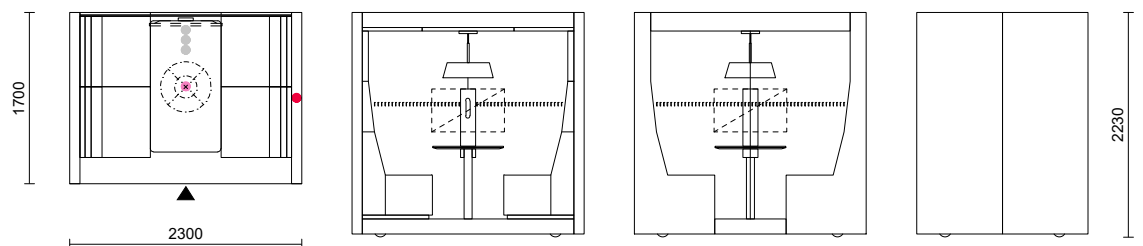



All our materials comply with M1 emission classification or similar.

MATERIAL DESCRIPTION

EXTERIOR	Melamine frame.
INTERIOR	Floor coated with carpet. Ceiling and wall covered with upholstered acoustic panels.
TABLE	MDF table with structural painted top and powder coated steel base.
WINDOW	Laminated acoustic safety glass window 10 mm. Glass window includes the INTO stripe window taping.

SURFACE FINISHES FOR POD ROOMS

STANDARD PRICE, CATEGORY 1

Melamine color options

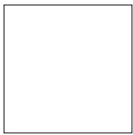

White



Dark grey

PRICE CATEGORY 2

Veneer material options

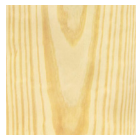

Pine

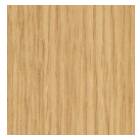

American oak



Black oak



The mark of responsible forestry

CARPETS FOR POD ROOMS: EX-DONO QUARTET FROM FLETCO | STANDARD PRICE, CATEGORY 1

Composition: Polyester non woven
Static electrical propensity: Antistatic
Impact sound reduction: 25 dB
Classification for use: Commercial / heavy use
Fire resistant: Yes



393300 393340 393350 393120 393260 393450 393550 393660 393750 393850

Ask for more colors: sales@intoconcept.com

COLOR OPTIONS FOR POD ROLL TABLE | STANDARD PRICE, CATEGORY 1

TABLE TOP

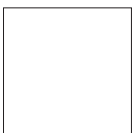

NCS S 0500-N
Structural

STEEL TUBE BASE



RAL 9016
white

SOFA FABRIC FOR POD ROLL: CURA FROM GABRIEL | STANDARD PRICE, CATEGORY 1

Composition: 100 % post-consumer recycled polyester
 Durability: 100 000 Martindale
 Lightfastness: 5-8
 Crocking: 4-5/wet, 4-5/dry
 Cleaning: vacuuming, wash and dry cleaning
 Fire resistant: Yes

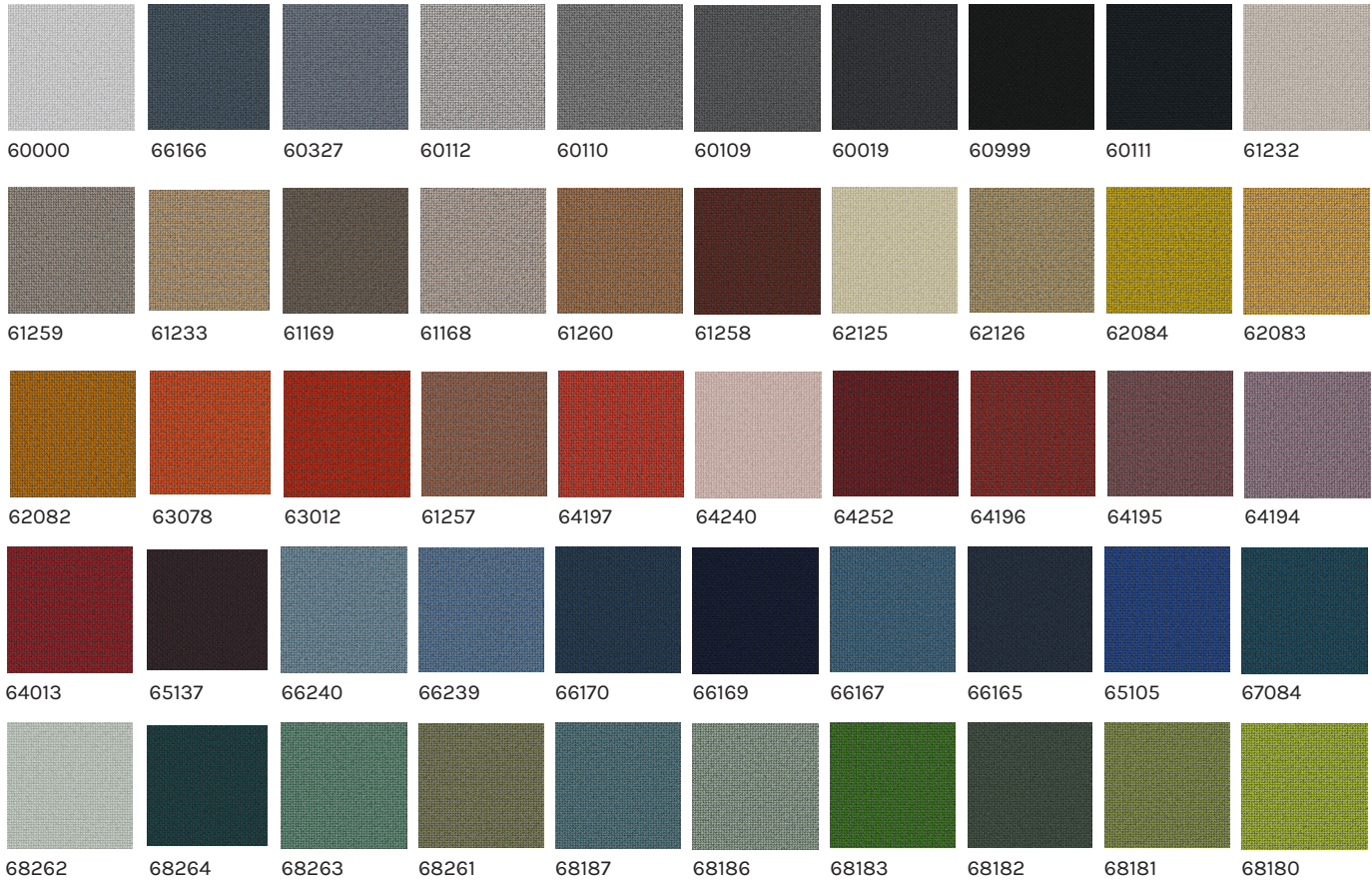

ANY OTHER FABRIC | PRICE CATEGORY 2

Ask for more fabrics: sales@intoconcept.com

POD ROLL GLASS

POD ROLL GLASS is a soundproof workspace for 2-4 people, ideal for spontaneous meetings and independent work.



TECHNICAL INFORMATION

Solution includes POINT sofas, table, ceiling lamp, screen holder, power sockets, and wheels.

AIR FLOW	Fully automated ventilation with electronic motion sensor. Switch for ventilation. Airflow rate of 44 l/s when occupied.
LIGHTING	Fully automated lights with electronic motion sensor. Switch for lights. Ceiling light. Lumen 2100.
WHEELS	Wheels under the POD ROLL GLASS make it easy to turn and move around if needed.
ENERGY CONSUMPTION	Total capacity 22,9 W. Fans capacity 8,9 W. Lights capacity 14 W. Max load 8 A.
SOCKET	One power socket on the tabletop + 3 under the table.
POWER CONNECTION	POD electricity connection from the ceiling or floor. The length of the power cord is 3 m.
SCREEN HOLDER	VESA mounting, does not include screen, max screen size 28".

MEASUREMENTS

EXTERNAL DIMENSIONS	W2300 x D1700 x H2230 mm
INNER DIMENSIONS	W2000 x D1640 x H1980 mm
TABLE	700 x 1100 x H730 mm
PACKAGE DIMENSIONS	2 x pallet: W1200 x D2500 x H1500 mm and W850 x D1700 x H2000 mm
WEIGHT	800 kg 205 kg/m ²

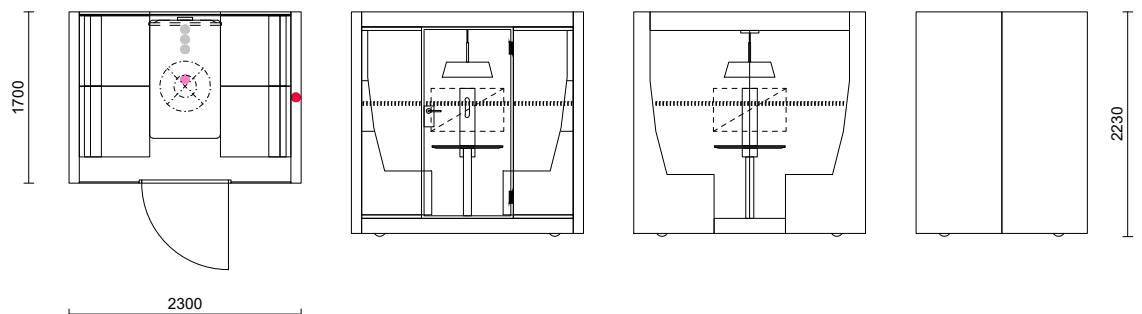



All our materials comply with M1 emission classification or similar.

MATERIAL DESCRIPTION

EXTERIOR	Melamine frame.
INTERIOR	Floor coated with carpet. Ceiling and wall covered with upholstered acoustic panels.
TABLE	MDF table with structural painted top and powder coated steel base.
WINDOW	Laminated acoustic safety glass window 10 mm. Glass window includes the INTO stripe window taping.
DOOR	Clear glass 10 mm. Door handle with satin finished stainless steel.

SURFACE FINISHES FOR POD ROOMS

STANDARD PRICE, CATEGORY 1

Melamine color options



White Dark grey

PRICE CATEGORY 2

Veneer material options



Pine American oak Black oak



CARPETS FOR POD ROOMS: EX-DONO QUARTET FROM FLETCO | STANDARD PRICE, CATEGORY 1

Composition: Polyester non woven
 Static electrical propensity: Antistatic
 Impact sound reduction: 25 dB
 Classification for use: Commercial / heavy use
 Fire resistant: Yes

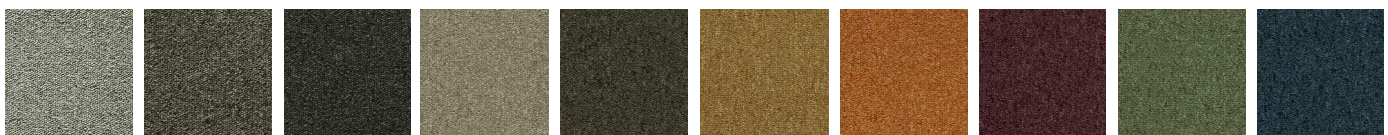

393300 393340 393350 393120 393260 393450 393550 393660 393750 393850

Ask for more colors: sales@intoconcept.com

COLOR OPTIONS FOR POD ROLL GLASS TABLE | STANDARD PRICE, CATEGORY 1

TABLE TOP

STEEL TUBE BASE

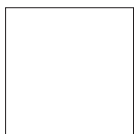

NCS S 0500-N
Structural

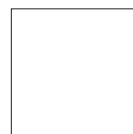

RAL 9016
white

SOFA FABRIC FOR POD ROLL GLASS: CURA FROM GABRIEL | STANDARD PRICE, CATEGORY 1

Composition: 100 % post-consumer recycled polyester
 Durability: 100 000 Martindale
 Lightfastness: 5-8
 Crocking: 4-5/wet, 4-5/dry
 Cleaning: vacuuming, wash and dry cleaning
 Fire resistant: Yes



ANY OTHER FABRIC | PRICE CATEGORY 2

Ask for more fabrics: sales@intoconcept.com

POD ROLL GLASS SMALL

POD ROLL GLASS SMALL is a quiet meeting pod for two people, ideal for spontaneous meetings. It is a timeless and easily movable solution for focused conversations.



TECHNICAL INFORMATION

Solution includes POINT sofas, table, ceiling lamp, power sockets, screen holder and wheels.

AIR FLOW	Fully automated ventilation with electronic motion sensor. Switch for ventilation. Air flow 44l/s.
LIGHTS	Fully automated lights with electronic motion sensor. Switch for lights. Ceiling light. Lumen 2100.
WHEELS	Wheels under the POD ROLL GLASS SMALL make it easy to turn and move around if needed.
ENERGY CONSUMPTION PER HOUR	Total 22,9 W. Fans 8,9 W. Lights 14 W. Max load 8 A.
SOCKET	Two power sockets on the tabletop.
POWER CONNECTION	From the ceiling or floor. The length of the power cord is 3 m.
MEASUREMENTS	
EXTERNAL DIMENSIONS	W2300 x D1200 x H2230 mm
INNER DIMENSIONS	W2000 x D1170 x H1980 mm
TABLE	W700 x D650 x H730 mm
PACKAGE DIMENSIONS	2 x pallet: W800 x L2300 x H1400 mm and W800 x L1500 x H1000 mm
WEIGHT	580 kg

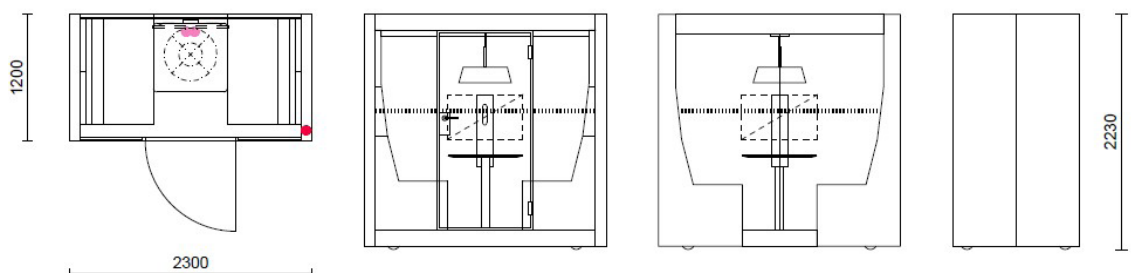



All our materials comply with M1 emission classification or similar.

MATERIAL DESCRIPTION

EXTERIOR	Melamine frame.
INTERIOR	Floor coated with carpet. Ceiling and wall covered with upholstered acoustic panels.
TABLE	MDF table with structural painted top and powder coated steel base.
WINDOW	Laminated acoustic safety glass window 10 mm. Glass window includes the INTO stripe window taping.
DOOR	Clear glass 10 mm. Door handle with satin finished stainless steel.

SURFACE FINISHES FOR POD ROOMS

STANDARD PRICE, CATEGORY 1

Melamine color options



White Dark grey

PRICE CATEGORY 2

Veneer material options

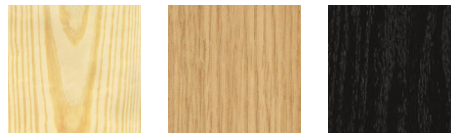

Pine American oak Black oak



CARPETS FOR POD ROOMS: EX-DONO QUARTET FROM FLETCO | STANDARD PRICE, CATEGORY 1

Composition: Polyester non woven
 Static electrical propensity: Antistatic
 Impact sound reduction: 25 dB
 Classification for use: Commercial / heavy use
 Fire resistant: Yes

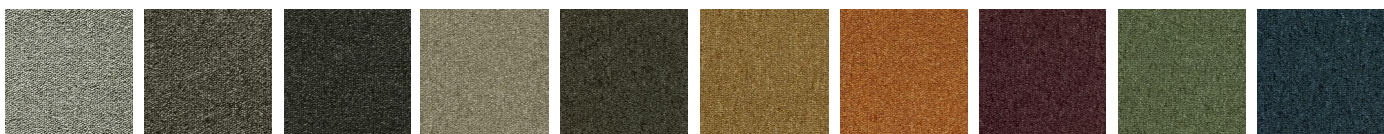
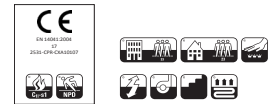

393300 393340 393350 393120 393260 393450 393550 393660 393750 393850

Ask for more colors: sales@intoconcept.com

COLOR OPTIONS FOR POD ROLL GLASS SMALL TABLE | STANDARD PRICE, CATEGORY 1

TABLE TOP



NCS S 0500-N
Structural

STEEL TUBE BASE



RAL 9016
white

SOFA FABRIC FOR POD ROLL GLASS SMALL: CURA FROM GABRIEL | STANDARD PRICE, CATEGORY 1

Composition: 100 % post-consumer recycled polyester
 Durability: 100 000 Martindale
 Lightfastness: 5-8
 Crocking: 4-5/wet, 4-5/dry
 Cleaning: vacuuming, wash and dry cleaning
 Fire resistant: Yes

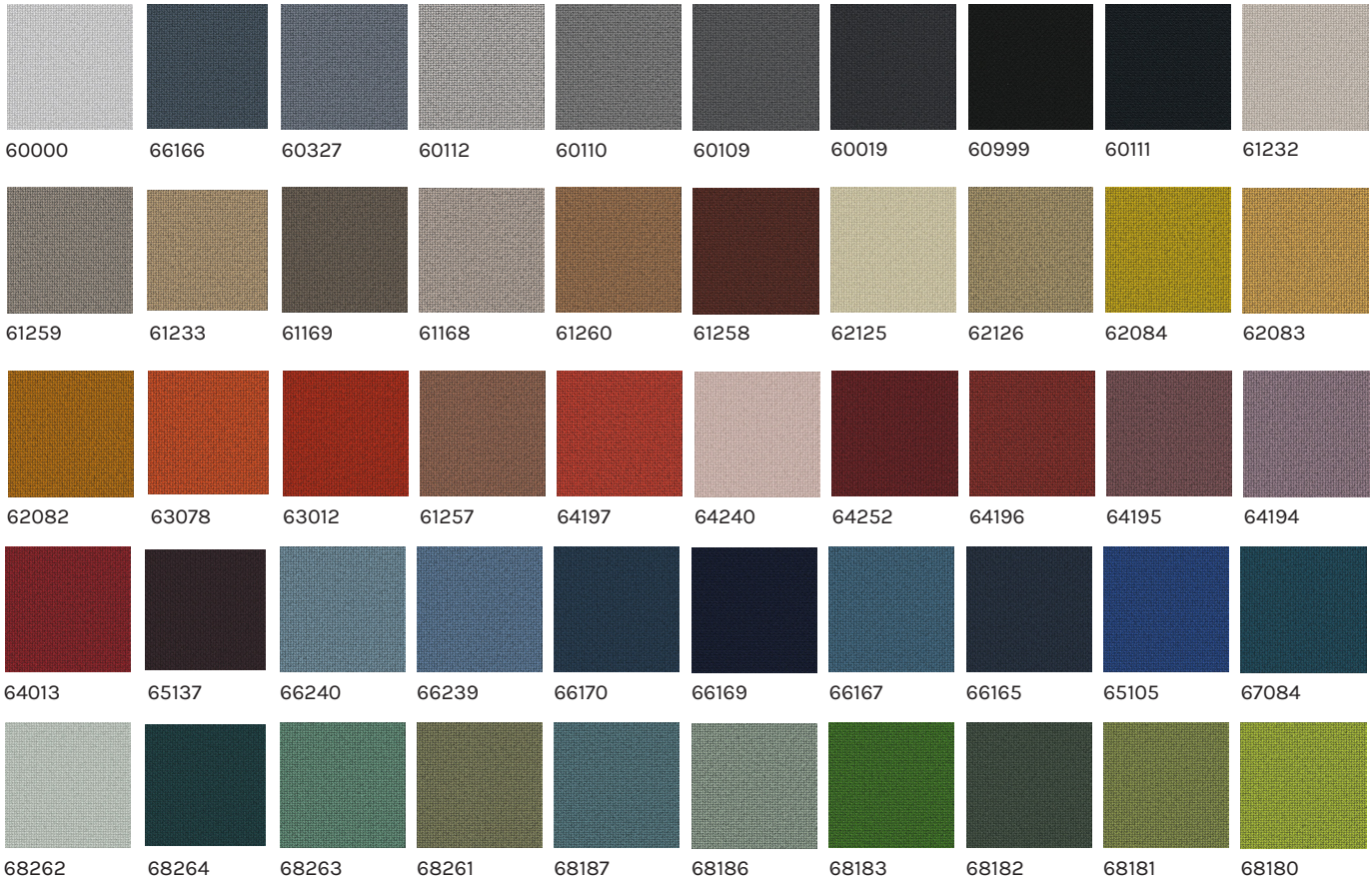

ANY OTHER FABRIC | PRICE CATEGORY 2

Ask for more fabrics: sales@intoconcept.com

POD PANEL

POD PANEL is an acoustic wall panel and an accessory for our POD rooms that helps you create a comfortable and sound-friendly work environment inside and outside the pod.



TECHNICAL INFORMATION

Easy to attach to the the POD with effortless fastening system.

MATERIAL DESCRIPTION

Plywood frame with acoustic wool.
Fully upholstered.

MEASUREMENTS

L500/600 x S45 x K2220 mm

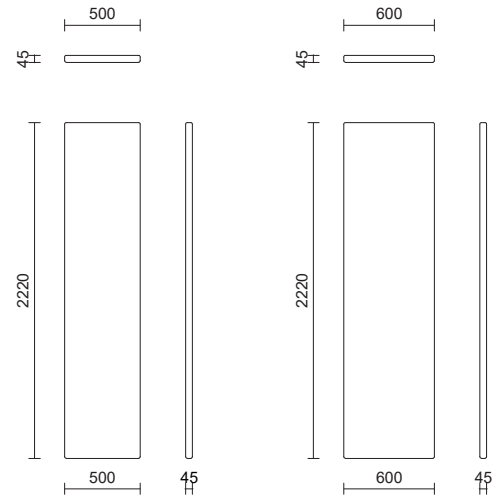

POD PANEL FABRIC: SOUL FROM GABRIEL | STANDARD PRICE, CATEGORY 1

Composition: 100% wool
 Lightfastness: 5-7
 Rubbing fastness: 4/wet, 4-5/dry
 Sustainability: Complies with STANDARD 100 by OEKO-TEX
 Meet Möbelfakta requirements
 Cleaning: regular vacuum cleaning
 Fire resistant: Yes (S 476 Part 7, class 1 ÖNORM B 3825-B1-3800-Q1 UK)



All our materials comply with M1 emission classification or similar.

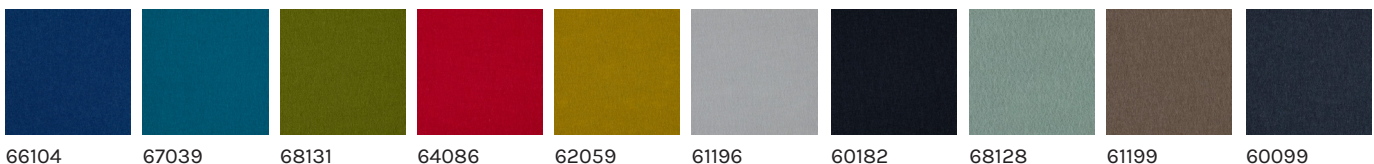

66104 67039 68131 64086 62059 61196 60182 68128 61199 60099

WHEELCHAIR RAMP

In accordance with accessibility standards, a wheelchair ramp can be installed into the POD rooms, as well as reservation for the automatic door.

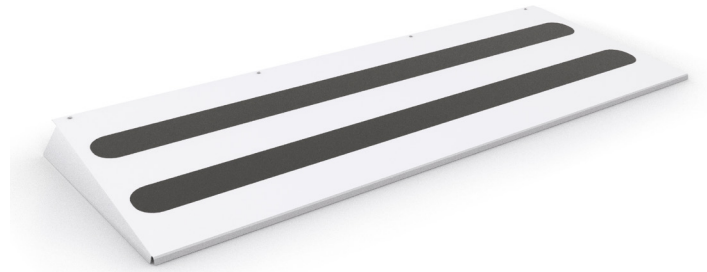

TECHNICAL INFORMATION	Available for POD rooms 1-4, POD MAX
MATERIAL DESCRIPTION	Powder-coated steel with grip tape.
MEASUREMENTS	According to the door width.

STANDARD COLOR FOR WHEELCHAIR RAMP

STANDARD PRICE, CATEGORY 1

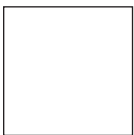

RAL 9016
white



RAL 7005
grey

Ask for more colors!

DISPLAY BOX

DISPLAY BOX is a screen holder specially designed for the POD meeting rooms. This screen holder is not only stylish but also makes it possible to hide the disruptive cables and remote control.



TECHNICAL INFORMATION

Three electrical sockets.
TV screen and the wall mount brackets are not included.

MATERIAL DESCRIPTION

MDF board with water-based paint.

MEASUREMENTS

Up to 42" screen: W700 x D100 x H1400 mm

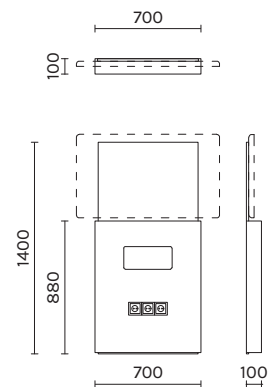

SURFACE FINISHES FOR DISPLAY BOX:



NCS S 9000-N
Structural

Ask for more colors!



All our materials comply with M1 emission classification or similar.



CUBE

CUBE sofa is designed for lobbies and office spaces, providing both acoustic and visual privacy. It is recommended to place two sofas facing each other, creating a comfortable and acoustically pleasant environment.



MATERIAL DESCRIPTION

Frame is fully upholstered with fabric.
Seat and backrest upholstered polyurethane foam.
Powder-coated steel tube base.

OPTIONS

An optional armrest with electrical socket is available.

MEASUREMENTS

W1600 x D710 x H1600 mm

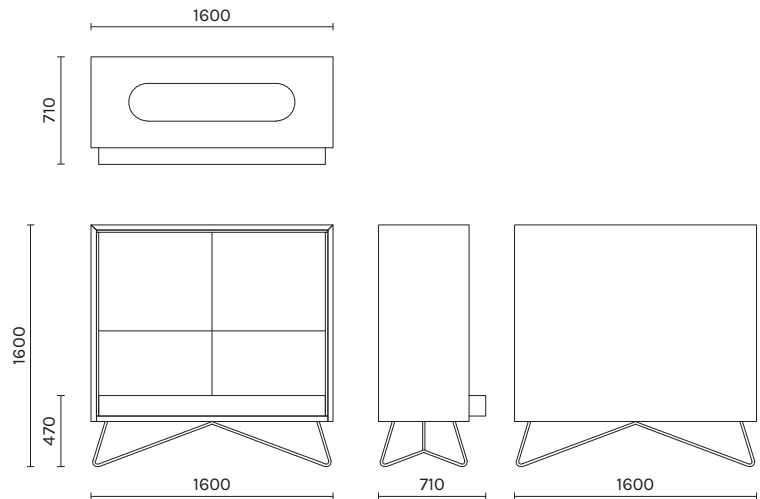



All our materials comply with M1 emission classification or similar.

CUBE ARMREST

TECHNICAL INFORMATION

Built-in electrical socket.
The length of the electric cord is 3 m.

MATERIAL DESCRIPTION

Veneer structure.
Upholstered with fabric.

MEASUREMENTS

W155 x D340 x H260 mm

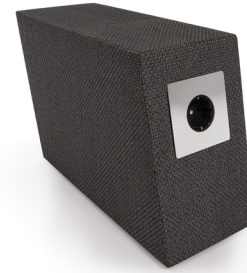

SOFA FABRIC FOR CUBE: CURA FROM GABRIEL | STANDARD PRICE, CATEGORY 1

Composition: 100 % post-consumer recycled polyester
Durability: 100 000 Martindale
Lightfastness: 5-8
Crocking: 4-5/wet, 4-5/dry
Cleaning: vacuuming, wash and dry cleaning
Fire resistant: Yes

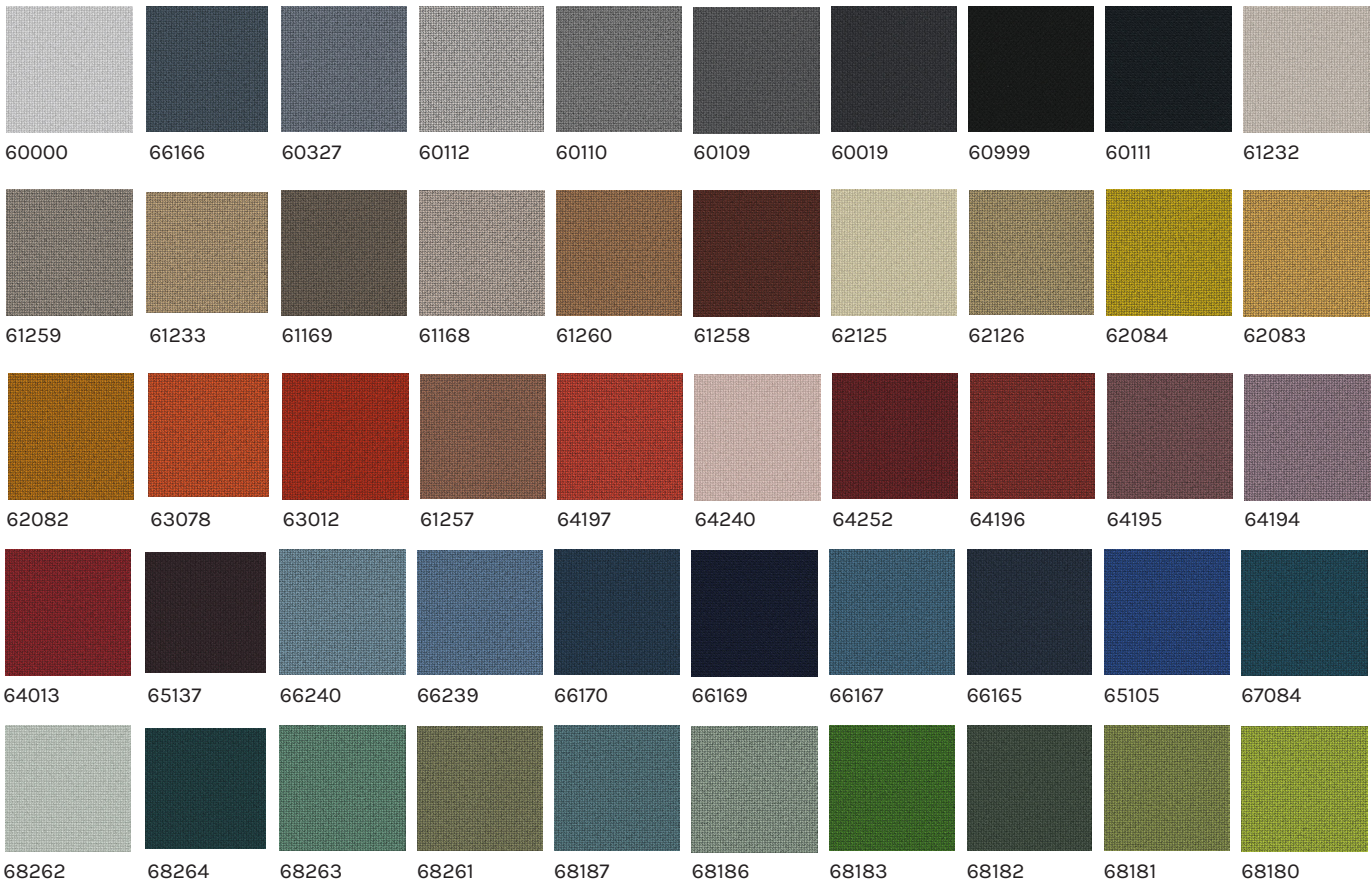

ANY OTHER FABRIC | PRICE CATEGORY 2

Ask for more fabrics: sales@intoconcept.com

CUBE SOLO

CUBE SOLO is a swivel lounge chair designed as an alternative to a phone booth in lobbies and office environments, offering both acoustic and visual privacy.



MATERIAL DESCRIPTION

Upholstered with fabric.
Seat and backrest upholstered polyurethane foam.
Powder-coated steel tube base.

OPTIONS

An optional armrest with electrical socket is available.

MEASUREMENTS

W800 x D710 x H1600 mm

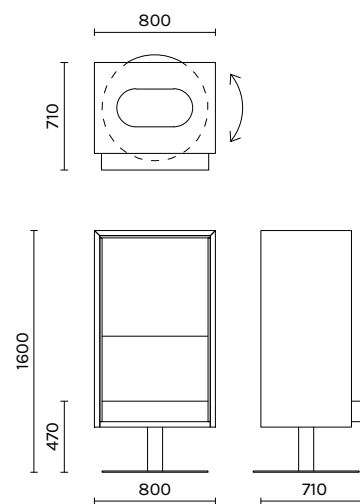



All our materials comply with M1 emission classification or similar.

CUBE SOLO ARMREST

TECHNICAL INFORMATION

Built-in electrical socket.
The length of the electric cord is 3 m.

MATERIAL DESCRIPTION

Veneer structure.
Upholstered with fabric.

MEASUREMENTS

W155 x D340 x H260 mm

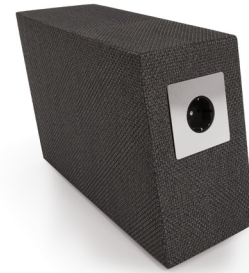

SOFA FABRIC FOR CUBE SOLO: CURA FROM GABRIEL | STANDARD PRICE, CATEGORY 1

Composition: 100 % post-consumer recycled polyester
Durability: 100 000 Martindale
Lightfastness: 5-8
Crocking: 4-5/wet, 4-5/dry
Cleaning: vacuuming, wash and dry cleaning
Fire resistant: Yes

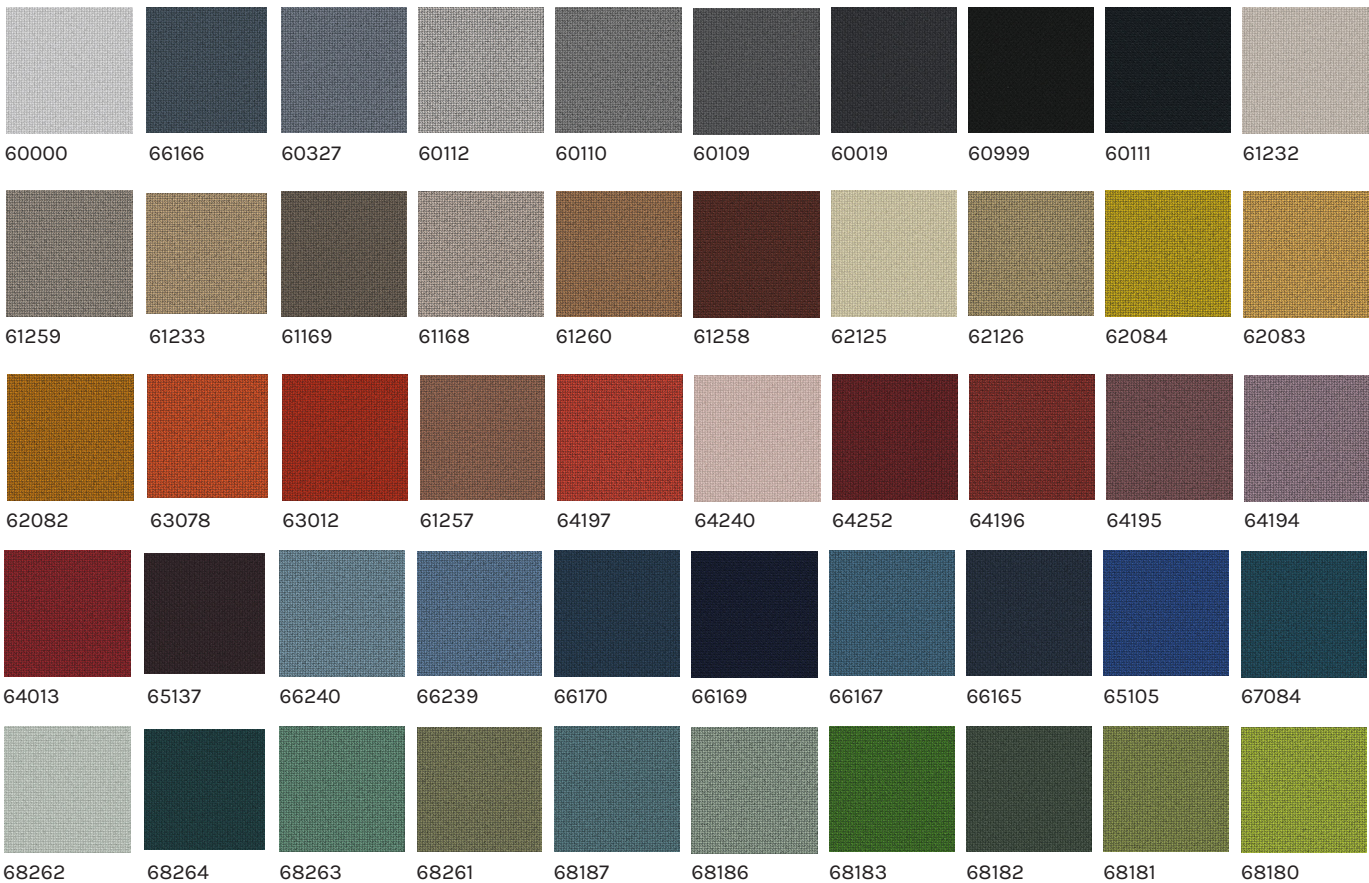

ANY OTHER FABRIC | PRICE CATEGORY 2

Ask for more fabrics: sales@intoconcept.com

POINT STOOL SOFAS



POINT STOOL sofa modules are flexible furniture solutions for lobbies, break areas and meeting rooms. They are made of durable and comfortable materials and their modular design allows you to combine them in many different ways.

TECHNICAL INFORMATION

The seating measurements support healthy working positions.
Connectors included.

MATERIAL DESCRIPTION

Plywood frame.
Polyurethane foam.
Fabric upholstery.
Plastic legs.

OPTIONS

Integrated electrical sockets with the power cord length 5 m.
POINT STOOL sofas are available with lockable wheels and height adjustable metal legs.

MEASUREMENTS

POINT STOOL S / M / L

W500/700/1000 x D700 x H470 mm

Seat height:

470 mm

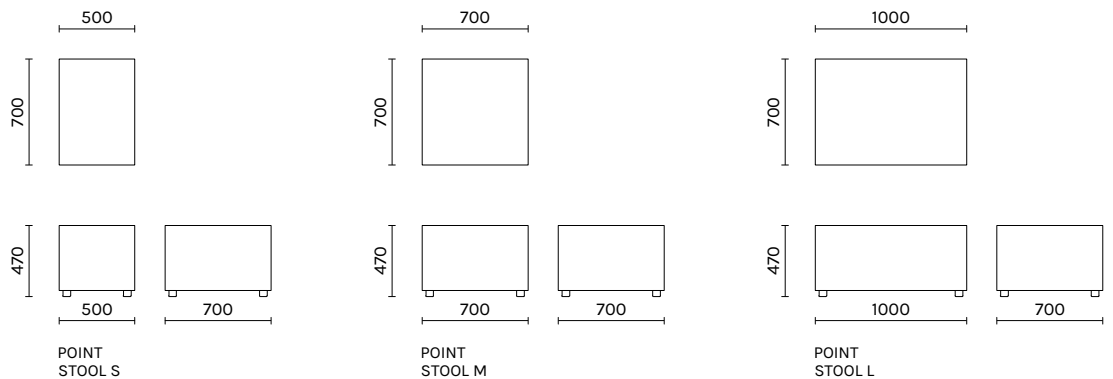



POINT LOW SOFAS

POINT LOW sofa modules are flexible furniture solutions for lobbies, break areas and meeting rooms. They are made of durable and comfortable materials and their modular design allows you to combine them in many different ways.

TECHNICAL INFORMATION

The seating measurements support healthy working positions.
Connectors included.

MATERIAL DESCRIPTION

Plywood frame.
Polyurethane foam.
Fabric upholstery.
Plastic legs.

OPTIONS

Integrated electrical sockets with the power cord length 5 m.
POINT LOW sofas are available with lockable wheels and height adjustable metal legs.

MEASUREMENTS

POINT LOW S / M / L
POINT CORNER LOW

W500/700/1000 x D700 x H920 mm
W700 x D700 x H920 mm

Seat height:

470 mm

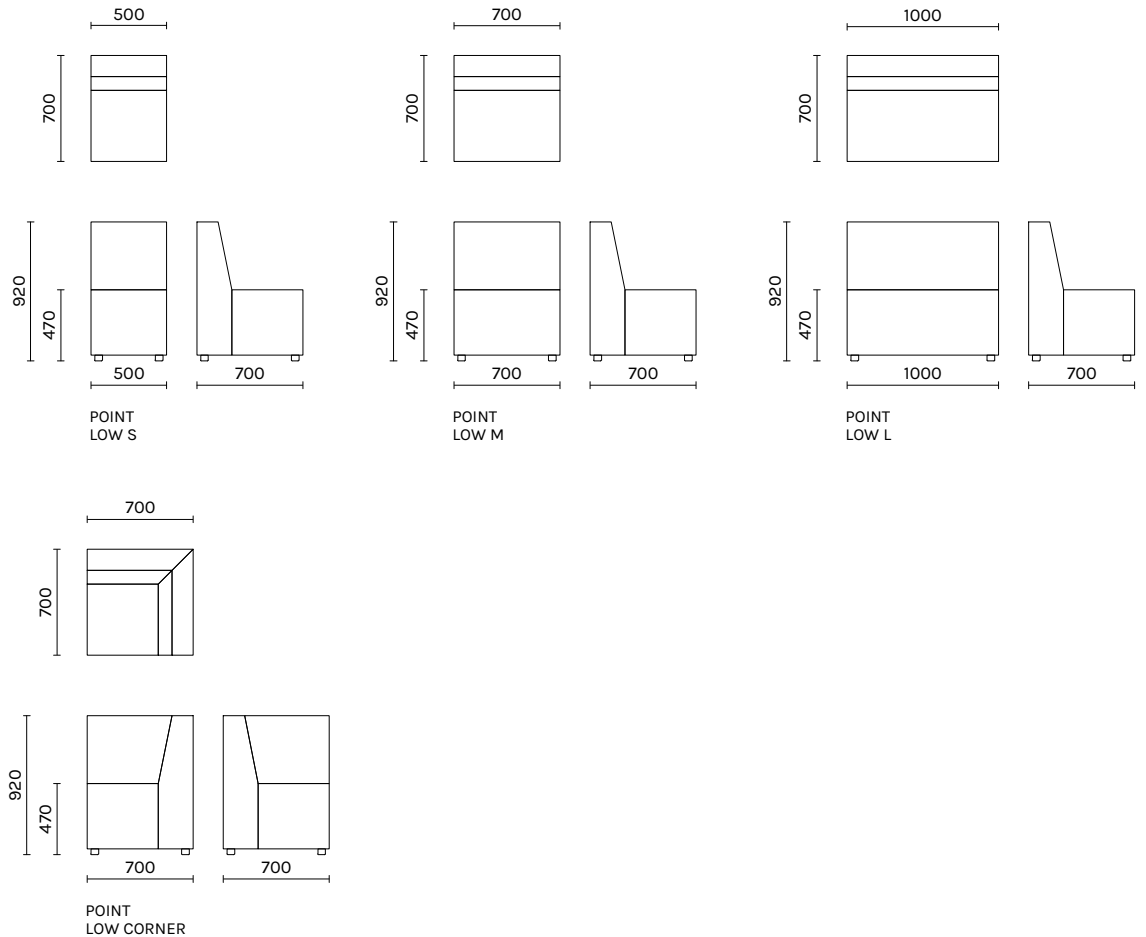

MEASUREMENTS

POINT CURVE IN LOW	W1020 x D700 x H920 mm
POINT CURVE OUT LOW	W1020 x D700 x H920 mm
POINT OUTER CORNER LOW, Left/Right	W1100 x D700 x H920 mm
Seat height:	470 mm

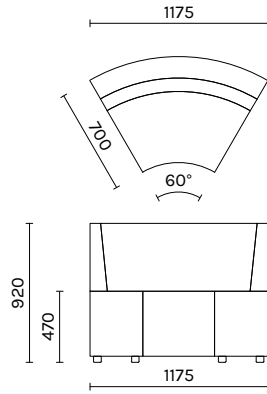

POINT
LOW CURVE IN

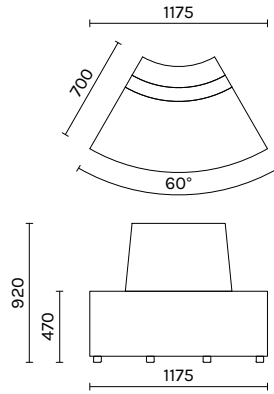

POINT
LOW CURVE OUT

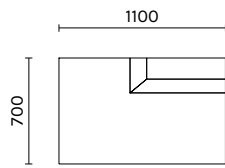

POINT
LOW OUTER CORNER LEFT

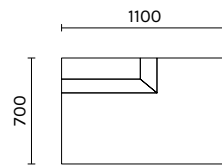

POINT
LOW OUTER CORNER RIGHT

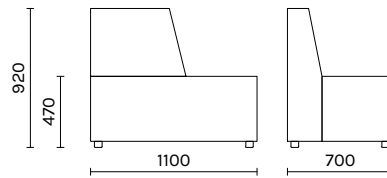
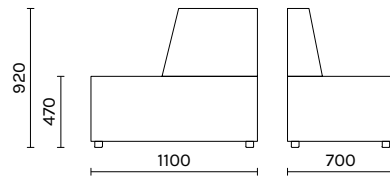

POINT HIGH SOFAS

POINT HIGH sofa modules are flexible furniture solutions for lobbies, break areas and meeting rooms. They are made of durable and comfortable materials and their modular design allows you to combine them in many different ways.



TECHNICAL INFORMATION

The seating measurements support healthy working positions.
Connectors included.

MATERIAL DESCRIPTION

Plywood frame.
Polyurethane foam.
Fabric upholstery.
Plastic legs.

OPTIONS

Integrated electrical sockets with the power cord length 5 m.
POINT HIGH sofas are available with lockable wheels and height adjustable metal legs.

MEASUREMENTS

POINT HIGH S / M / L
POINT CORNER HIGH

W500/700/1000 x D700 x H1420 mm
W700 x D700 x H1420 mm

Seat height:

470 mm

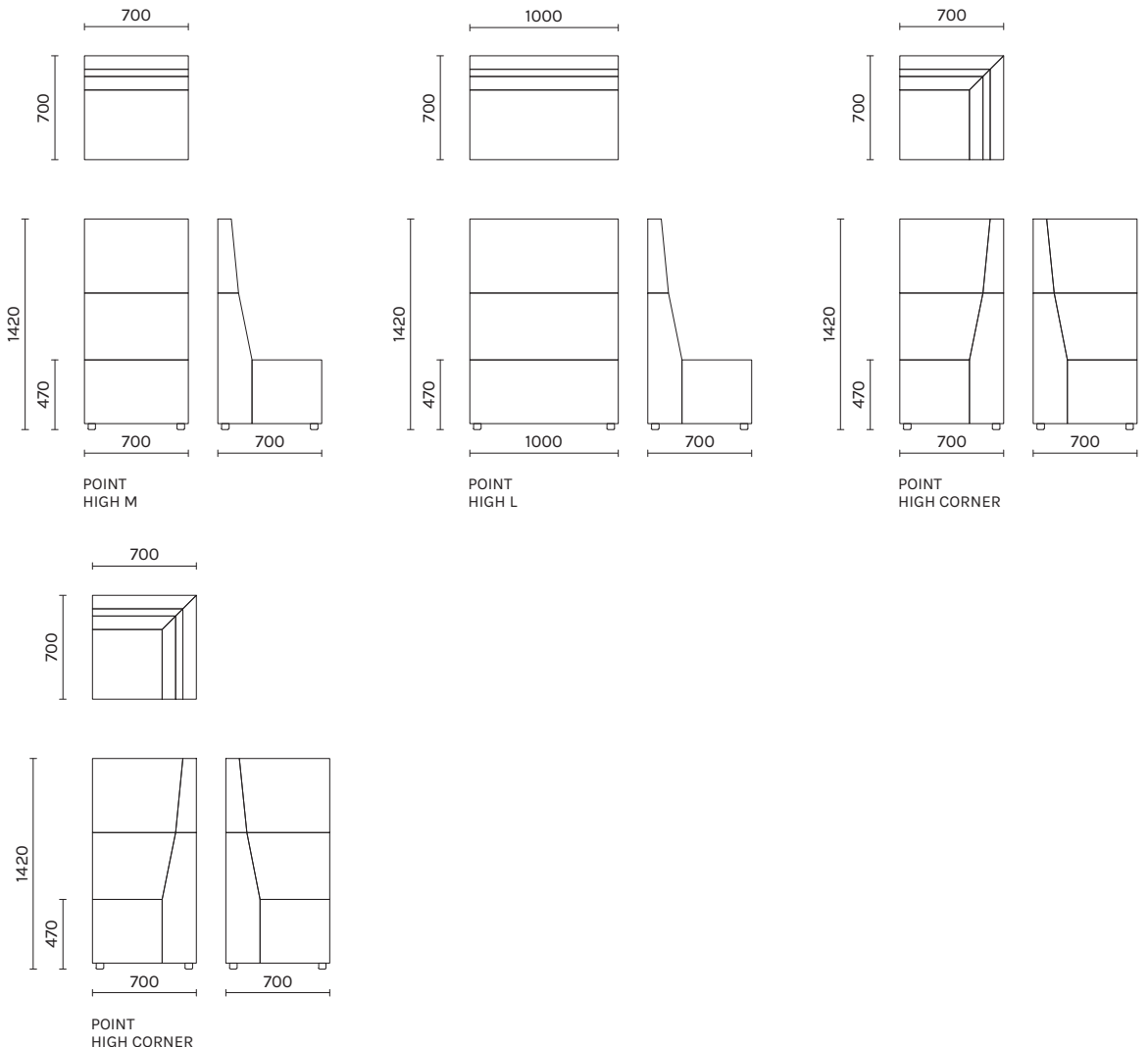

MEASUREMENTS

POINT CURVE IN HIGH
POINT CURVE OUT HIGH
POINT OUTER CORNER HIGH, Left/Right

W1020 x D700 x H1420 mm
W1020 x D700 x H1420 mm
W1100 x D700 x H1420 mm

Seat height:

470 mm

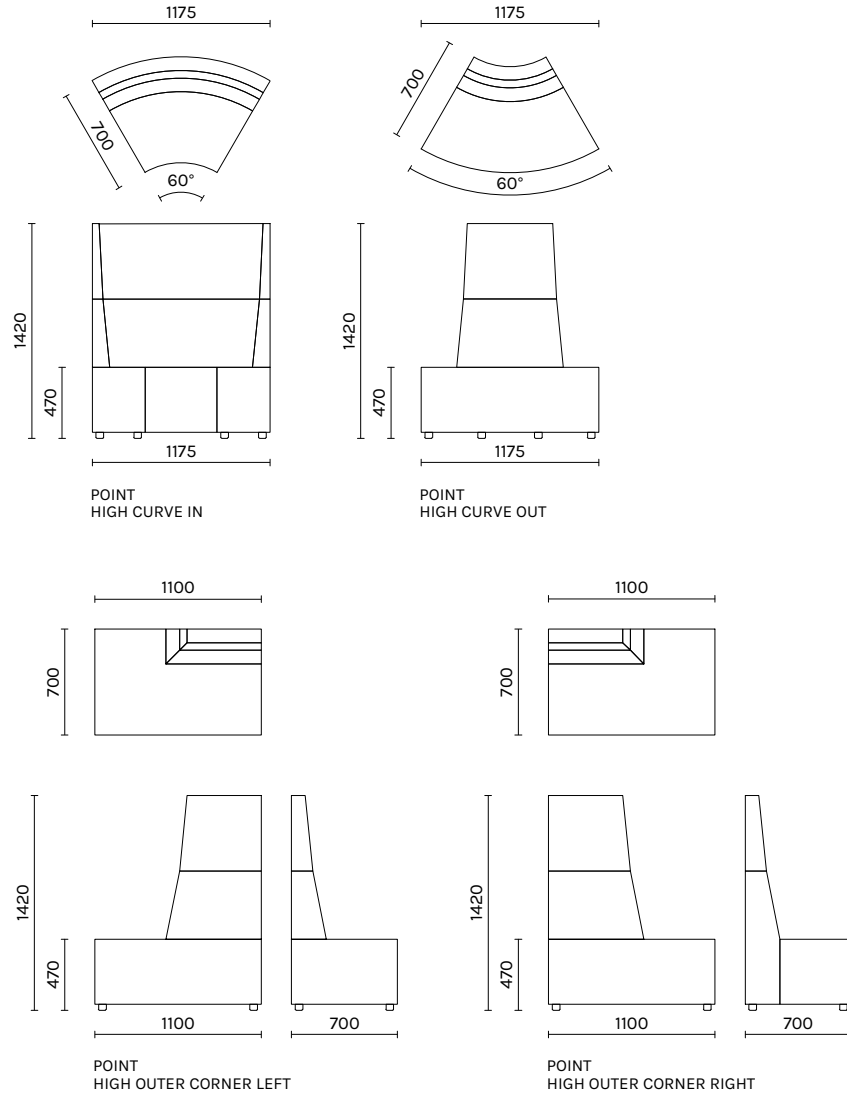



POINT SOFAS - COMBINING EXAMPLES

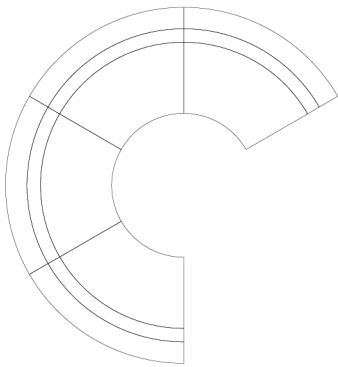

CURVE IN X 4

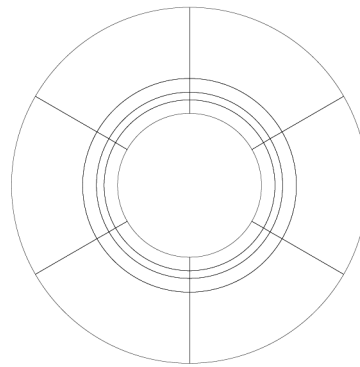

CURVE OUT X 6

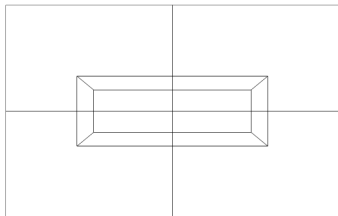

OUTER CORNER RIGHT X 2
OUTER CORNER LEFT X 2

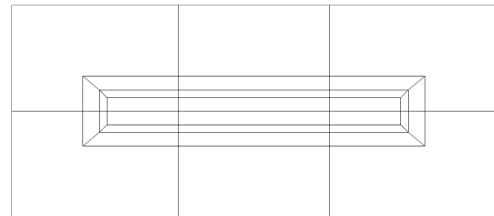

OUTER CORNER RIGHT X 2
OUTER CORNER LEFT X 2
POINT L X 2

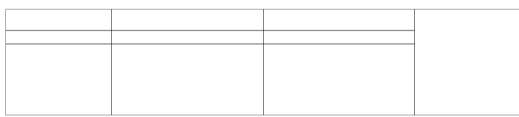

POINT M X 1
POINT L X 2
STOOL M X 1

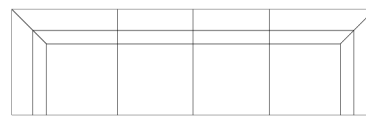

POINT CORNER X 2
POINT S X 2

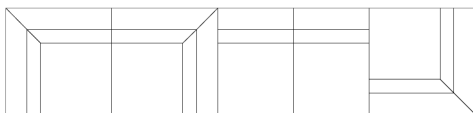

POINT CORNER X 3
POINT S X 2

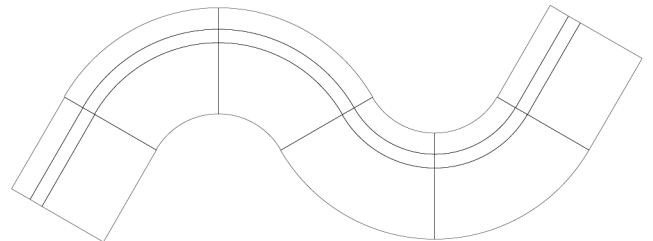

CURVE IN X 2
CURVE OUT X 2
POINT M X 2



All our materials comply with M1 emission classification or similar.

SOFA FABRIC FOR POINT SOFAS: CURA FROM GABRIEL | STANDARD PRICE, CATEGORY 1

Composition: 100 % post-consumer recycled polyester
 Durability: 100 000 Martindale
 Lightfastness: 5-8
 Crocking: 4-5/wet, 4-5/dry
 Cleaning: vacuuming, wash and dry cleaning
 Fire resistant: Yes



ANY OTHER FABRIC | PRICE CATEGORY 2

Ask for more fabrics: sales@intoconcept.com

POINT BOX TABLE

POINT BOX TABLE is an add-on side table for POINT sofas, providing extra surface and storage space. It includes a table lamp and a power socket, bringing both function and cozy atmosphere.



TECHNICAL INFORMATION

Sofa connectors included.

LIGHTS

Table lamp with a switch.
Lumen 1055.

ENERGY CONSUMPTION

Lights 0,007 kWh.
Max load 6A.

SOCKET

One USB-C power socket on the tabletop.

POWER CONNECTION

The length of the electric cord is 3 m.

OPTIONS

Available without a table lamp.

MATERIAL DESCRIPTION

Oak veneered MDF frame.
Plastic legs.
Steel table lamp base and plastic lamp shade.
Steel sofa connectors.
White power socket.

MEASUREMENTS

W280 x D680 x H450 mm
Height with table lamp H1510 mm

PACKAGE DIMENSIONS

W1100 x D500 x H300 mm

WEIGHT

19 kg

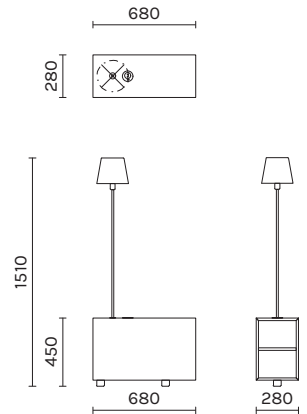

SURFACE FINISHES FOR POINT BOX TABLE:

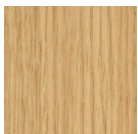

Oak



All our materials comply with M1 emission classification or similar.



The mark of responsible forestry

POINT CUP

POINT CUP office booth is a sound-friendly 360-degree furniture solution that offers a comfortable space for presentations and video conferences.



TECHNICAL INFORMATION

SOCKETS One electrical socket on the table + 3 sockets in the screen wall.

SCREEN Screen wall is suitable for 20-42" screen.
Screen wall does not include screen nor bracket for it.

ELECTRICITY CONNECTION The length of the electric cord for the POINT CUP solution is 3 m.

MATERIAL DESCRIPTION Office booth sofa modules with plywood frame, polyurethane foam and fabric upholstery.
Table with structural paint top and powder-coated steel base.
Base board painted MDF.
Screen wall painted MDF and felt from the back.

OPTIONS Tabletop with laminate.

MEASUREMENTS W2350 x D2480 x H1410 mm
TOP CUP table Ø900 / H720 mm

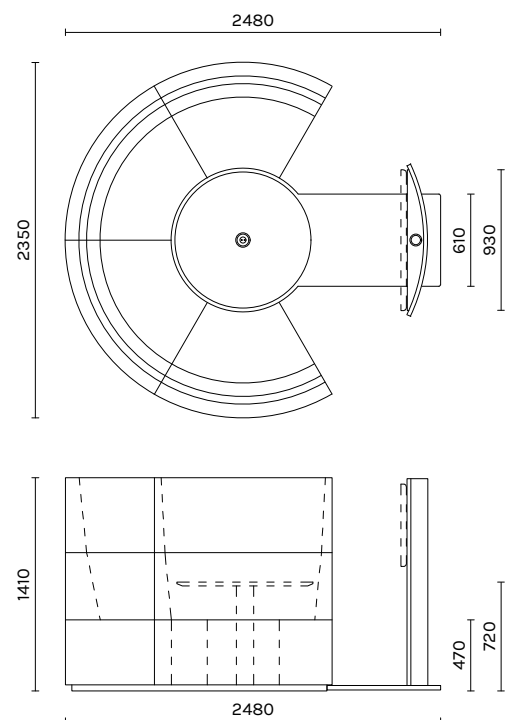



All our materials comply with M1 emission classification or similar.

SOFA FABRIC FOR POINT CUP: CURA FROM GABRIEL | STANDARD PRICE, CATEGORY 1

Composition: 100 % post-consumer recycled polyester
 Durability: 100 000 Martindale
 Lightfastness: 5-8
 Crocking: 4-5/wet, 4-5/dry
 Cleaning: vacuuming, wash and dry cleaning
 Fire resistant: Yes



ANY OTHER FABRIC | PRICE CATEGORY 2

Ask for more fabrics: sales@intoconcept.com

COLOR OPTIONS FOR POINT CUP TABLE

STANDARD PRICE, CATEGORY 1



NCS S 0500-N
Structural

PRICE CATEGORY 2



White
lamine

STEEL TUBE BASE | STANDARD PRICE, CATEGORY 1

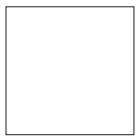

RAL 9016

FELT FOR POINT CUP SCREEN WALL: FULDA FIT FROM FILZFABRIK | STANDARD PRICE, CATEGORY 1

Composition: 30% Polyamid, 70% Polypropylen

Static electrical propensity: Antistatic

Classification for use: Commercial / heavy use

Fire resistant: Yes

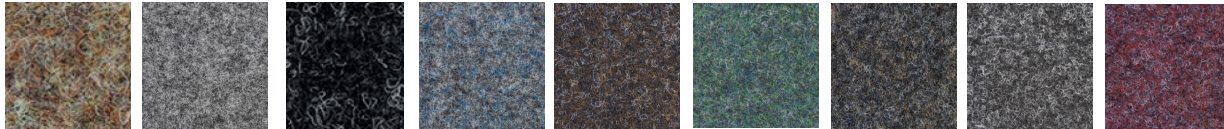

37

61

69

52

75

85

66

63

16

SCREEN WALL COLOR | STANDARD PRICE, CATEGORY 1



NCS S 0500-N
Smooth

BASEBOARD COLOR | STANDARD PRICE, CATEGORY 1



NCS S 0500-N
Structural



TOP TABLES

TOP TABLES are visually slender yet structurally steady table solutions that enable ergonomic and flexible work. Table sizes go from small laptop tables up to bigger working desks.

TECHNICAL INFORMATION

Available either fixed leg or height-adjustable leg.
Height is adjusted with a gas spring from a handle installed on the edge of the table top.

MATERIAL DESCRIPTION

MDF table top painted with structural paint.
Base powder coated steel.

OPTIONS

Table top with laminate, nano-laminate, pine or oak.

TESTED

TOP tables are tested and approved according with standard EN 15372:2016 which is European furniture standard testing strength, durability, and safety.

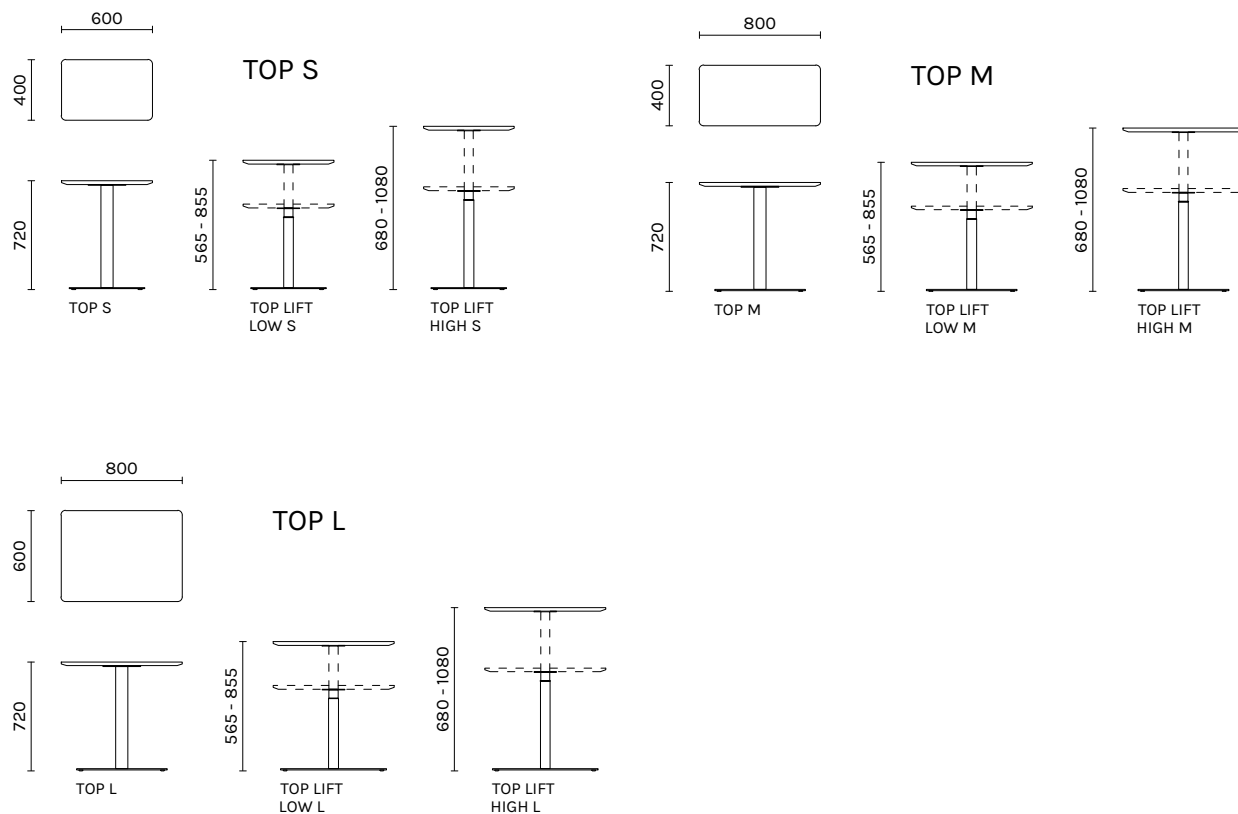

TOP WORK

TOP WORK table is a visually slender yet structurally steady desk designed for ergonomic and flexible work. It is height-adjustable with a gas mechanism, so you can easily switch between sitting and standing.



TECHNICAL INFORMATION

Height is adjusted with a gas spring from a handle installed on the edge of the table top.

MATERIAL DESCRIPTION

MDF table top painted with structural paint.
Base powder coated steel.

OPTIONS

Table top with laminate, nano-laminate, pine or oak.

TESTED

TOP WORK tables are tested and approved according with standard EN 15372:2016 which is European furniture standard testing strength, durability, and safety.

MEASUREMENTS

W1000 x D500 x H680-1080 mm

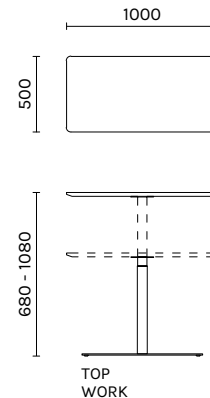

TOP WORK

TOP ROUND TABLES

TOP ROUND TABLES are visually slender yet structurally steady table solutions that enable ergonomic and flexible work. Table sizes range from compact laptop, sofa or side tables to larger work desks.



TECHNICAL INFORMATION

Available either fixed leg or height-adjustable leg. Height is adjusted with a gas spring from a handle installed on the edge of the table top.

MATERIAL DESCRIPTION

MDF table top painted with structural paint. Base powder coated steel.

OPTIONS

Table top with laminate, nano-laminate, pine or oak.

TESTED

TOP ROUND tables are tested and approved according with standard EN 15372:2016 which is European furniture standard testing strength, durability, and safety.

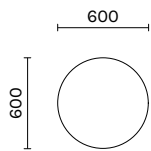

TOP ROUND S

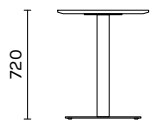

TOP ROUND S

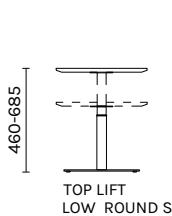

TOP LIFT LOW ROUND S

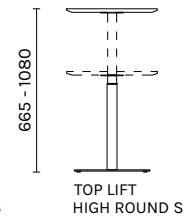

TOP LIFT HIGH ROUND S

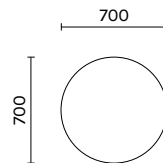

TOP ROUND M

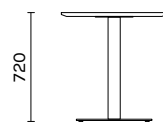

TOP ROUND M

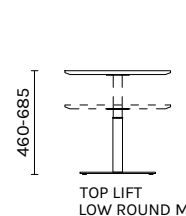

TOP LIFT LOW ROUND M

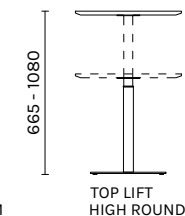

TOP LIFT HIGH ROUND M

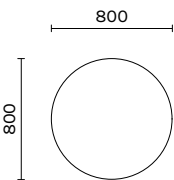

TOP ROUND L

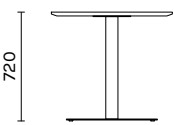

TOP ROUND L

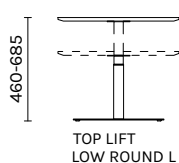

TOP LIFT LOW ROUND L

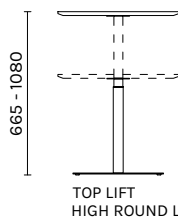

TOP LIFT HIGH ROUND L

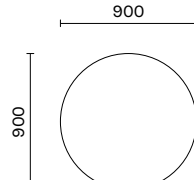

TOP ROUND XL

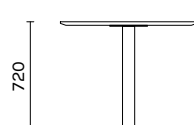

TOP ROUND XL

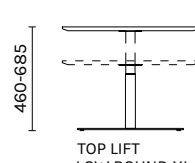

TOP LIFT LOW ROUND XL

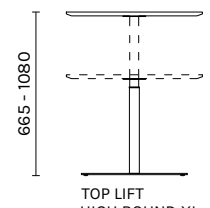

TOP LIFT HIGH ROUND XL

TOP CURVE TABLES

TOP CURVE TABLES are visually slender yet structurally steady table solutions that support ergonomic and flexible work. Their curved shape ensures a comfortable working position. The tables come in two different sizes.



TECHNICAL INFORMATION

Available either fixed leg or height-adjustable leg.
Height is adjusted with a gas spring from a handle installed on the edge of the table top.

MATERIAL DESCRIPTION

MDF table top painted with structural paint.
Base powder coated steel.

OPTIONS

Table top with laminate, nano-laminate, pine or oak.

TESTED

TOP CURVE tables are tested and approved according with standard EN 15372:2016 which is European furniture standard testing strength, durability, and safety.

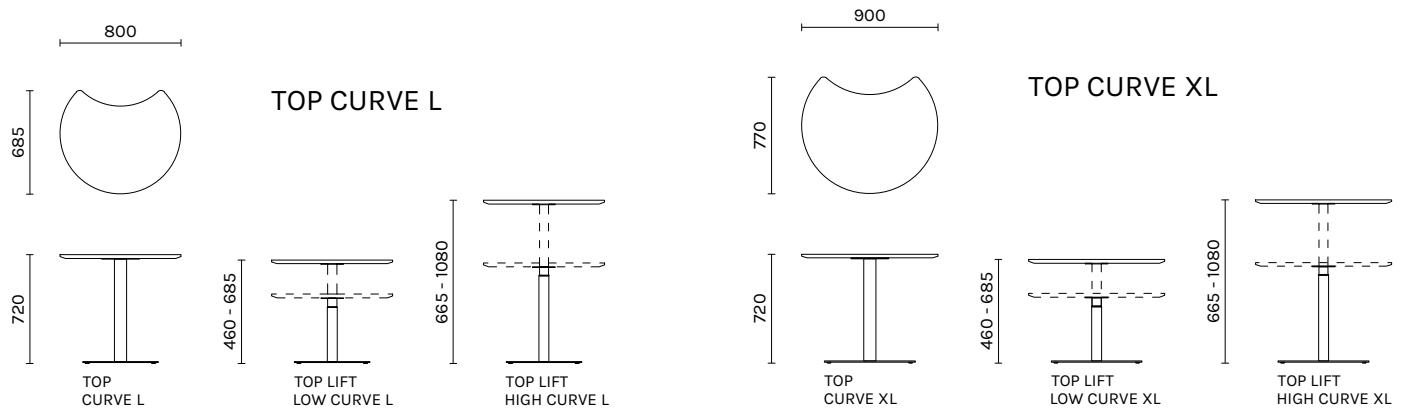

COLOR OPTIONS FOR ALL TOP TABLES

STANDARD PRICE, CATEGORY 1

Standard paint color options

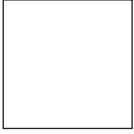

NCS S 0500-N
Structural

PRICE CATEGORY 2



White
laminat



Black
laminat



White nano-
laminat



Black nano-
laminat

PRICE CATEGORY 2



Oak veneer



Pine veneer



POWDER COATED STEEL TUBE BASE | STANDARD PRICE, CATEGORY 1

Standard base paint options

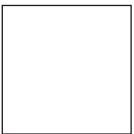

RAL 9016



RAL 9005



FOCUS

FOCUS is an acoustic and mobile workstation that offers privacy for focused work. It includes fixed lighting and a built-in electrical socket for added convenience and comfort.



TECHNICAL INFORMATION

Wheels included.
Table lamp with switch.
2 x electrical socket.
The electric cord length for the FOCUS solution is 3 m.

MATERIAL DESCRIPTION

Bent board frame.
Felt upholstered inside and outside.
Fixed table painted with structural paint.

MEASUREMENTS

W1530 x D1410 x H1580 mm

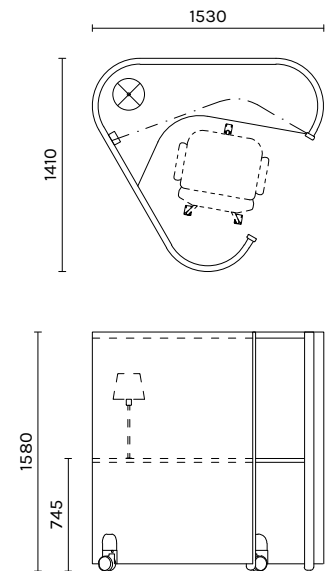



All our materials comply with M1 emission classification or similar.

FELT: FULDA FIT FROM FILZFABRIK | STANDARD PRICE, CATEGORY 1

Composition: 30% Polyamid, 70% Polypropylen
 Static electrical propensity: Antistatic
 Classification for use: Commercial / heavy use
 Fire resistant: Yes

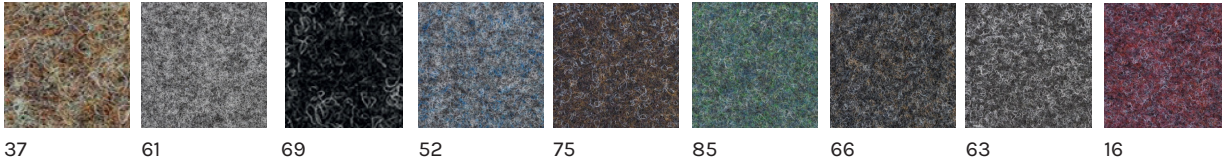

COLOR OPTION FOR THE TABLE | STANDARD PRICE, CATEGORY 1

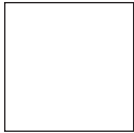

NCS S 0500-N
Structural



ROLL IN

ROLL IN is an acoustic and mobile workstation on wheels, providing a place for independent, focused work in the office or at home. It includes fixed lighting, a built-in electrical socket as well as two bag hooks under the table.



TECHNICAL INFORMATION

Lockable wheels included.
2 x built-in electrical socket.
2 x bag hooks under the table.
Light with switch.
The electric cord length for the ROLL IN solution is 3 m.

MATERIAL DESCRIPTION

MDF frame with tabletop painted with white structural paint or optionally veneer frame with veneer tabletop.
Base powder-coated steel.
Acrylic window.

MEASUREMENTS

W1150 x D680 x H1514 mm

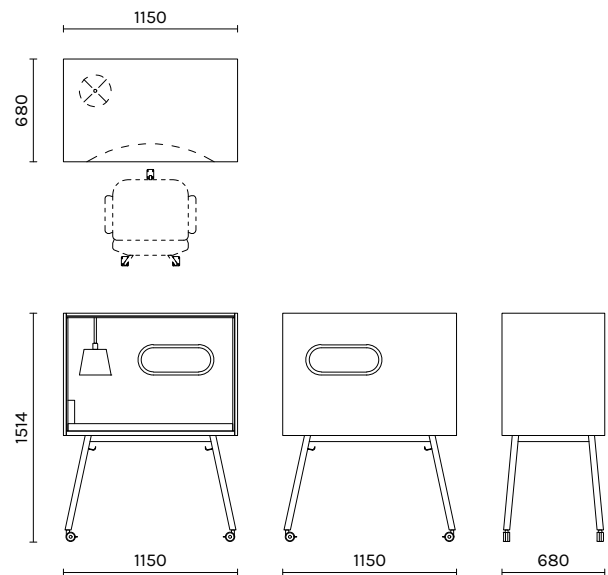



All our materials comply with M1 emission classification or similar.

SURFACE FINISHES FOR ROLL IN:

STANDARD PRICE, CATEGORY 1

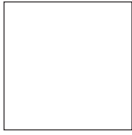

NCS S 0500-N
Smooth

PRICE CATEGORY 2



Pine veneer

PRICE CATEGORY 3



Oak veneer



The mark of responsible forestry

INSIDE PANEL FABRIC: SOUL FROM GABRIEL | STANDARD PRICE, CATEGORY 1

Composition: 100% wool
 Lightfastness: 5-7
 Rubbing fastness: 4/wet, 4-5/dry
 Sustainability: Complies with STANDARD 100 by OEKO-TEX
 Meet Möbelfakta requirements
 Cleaning: regular vacuum cleaning
 Fire resistant: Yes (S 476 Part 7, class 1 ÖNORM B 3825-B1-3800-Q1 UK)



66104 67039 68131 64086 62059 61196 60182 68128 61199 60099

STEEL TUBE BASE | STANDARD PRICE, CATEGORY 1

Standard base paint options



RAL 9016

RAL 9005



HUT

HUT is a modular design solution that brings calmness to open spaces. Wall panels provide added visual privacy, and the modular design allows the solution to be replicated and adapted to different environments.



TECHNICAL INFORMATION	Comes with one small wall panel. Levelling screws under the pillars.
OPTIONS TO ADD	Wall panels for each side.
MATERIAL DESCRIPTION	Oiled pine slats. Steel base with powder paint finish. Fabric upholstered wall panel.
MEASUREMENTS	W2450 x D1250 x H2220 mm Slats W2450 x D1250 mm Wall panels: Small W1705 x H2220 mm Long W2450 x H2220 mm
PACKAGE DIMENSIONS	W1250 x D1250 x H500 mm
WEIGHT	51 kg

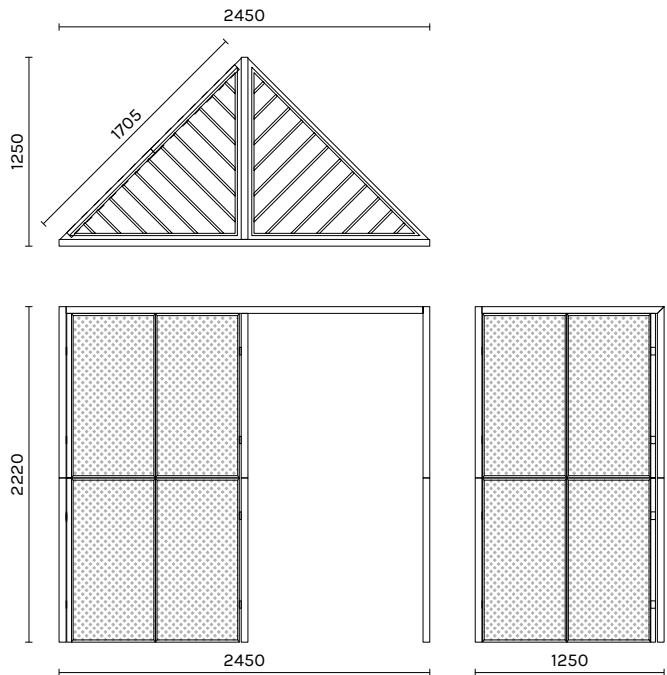

HUT - WALL PANELS

HUT is a modular design solution comes with one small wall panel. Additional wall panels can be added.



SMALL

MEASUREMENTS

Small W1705 x H2220 mm

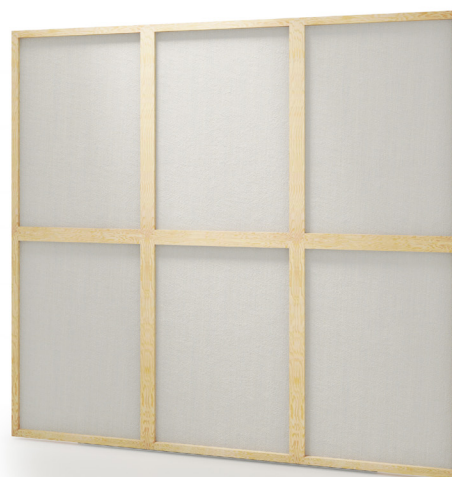

LONG

MEASUREMENTS

Long W2450 x H2220 mm



HUT - COMBINING EXAMPLES

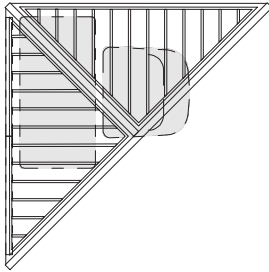

HUT x 1

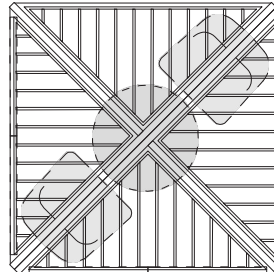

HUT x 2

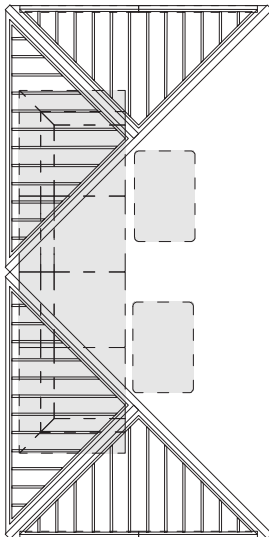

HUT x 2

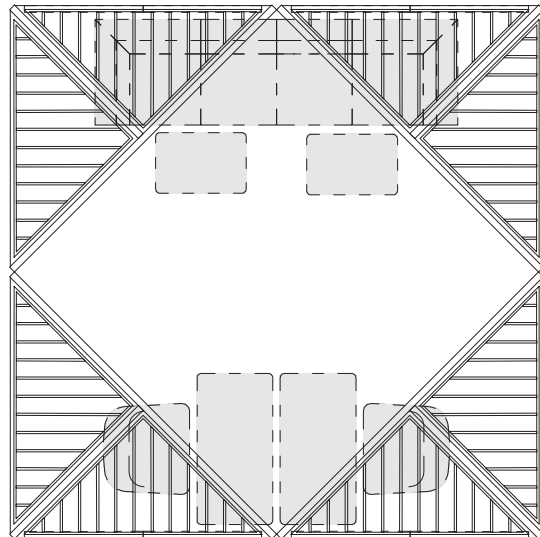

HUT x 4

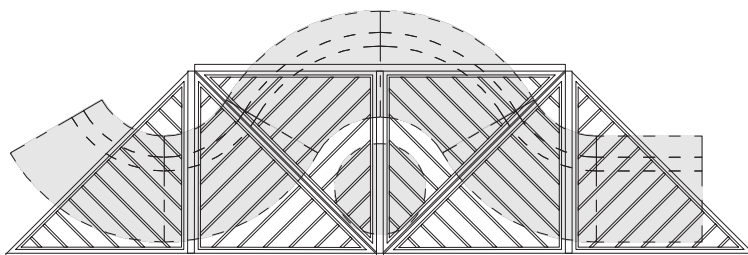

HUT x 3



All our materials comply with M1 emission classification or similar.

SURFACE FINISHES FOR HUT:

WOODEN SLATS | STANDARD PRICE, CATEGORY 1

Standard material options



Oiled pine



POWDER COATED STEEL BASE | STANDARD PRICE, CATEGORY 1

Standard base paint options

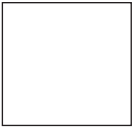

RAL 9016



RAL 9005



RAL 6002

UPHOLSTERY FABRIC FOR HUT PANELS: HALO FROM WANTED | CATEGORY 1

100% Trevira CS

Sustainability: Oeko-Tex Standard 100 certified

Cleaning: Vacuuming and dry cleaning

Fire resistant: yes

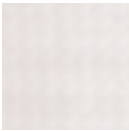

238 White



STORY WALL

STORY WALL is a versatile, mobile, modular acoustic space divider. They can be easily connected to each other with integrated magnetic connectors, and they can be moved flexibly as spatial needs change. A wide range of versatile add-ons are available.



TECHNICAL INFORMATION	Includes wheels and adjustable support legs.
MATERIAL DESCRIPTION	Plywood + chipboard frame filled with acoustical wool. Available with pine, oak and black oak veneer. Both sides upholstered with felt.
OPTIONS TO ADD	<ul style="list-style-type: none"> TV bracket Corner piece Whiteboard Marker tray Basketball hoop Ball shelf Dartboard Shelf Coat hanger Mug holder Magazine holder PLANT BOX

MEASUREMENTS	W 1190 x D600 x H2100 mm
---------------------	--------------------------

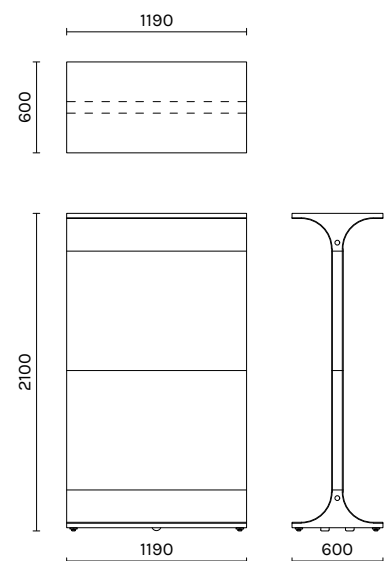

STORY WALL HIGH

STORY WALL HIGH is a versatile, mobile, modular acoustic space divider. They can be easily connected to each other with integrated magnetic connectors, and they can be moved flexibly as spatial needs change. A wide range of versatile add-ons are available.



TECHNICAL INFORMATION

Includes wheels and adjustable support legs.

MATERIAL DESCRIPTION

Plywood + chipboard frame filled with acoustical wool.
Available with pine, oak and black oak veneer.
Both sides upholstered with felt.

OPTIONS TO ADD

TV bracket
Corner piece
Whiteboard
Marker tray
Basketball hoop
Ball shelf
Dartboard
Shelf
Coat hanger
Mug holder
Magazine holder
PLANT BOX

MEASUREMENTS

W 1190 x D600 x H2900 mm

Minimum order quantity 2 pieces.

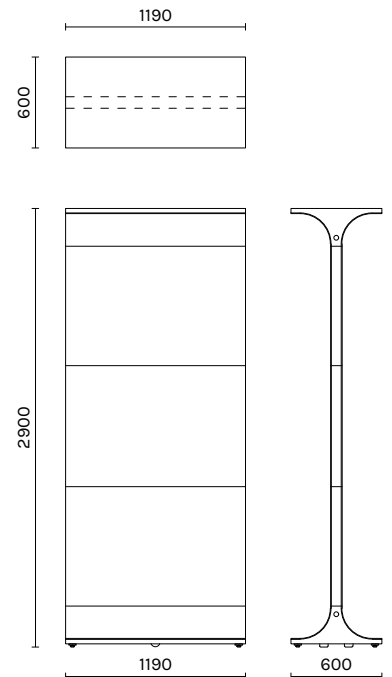

STORY WALL LOW

STORY WALL LOW is a versatile, movable, and modular acoustic room divider. Its low height makes it child-friendly while allowing clear visibility for adults. They can be easily connected to each other with integrated magnetic connectors, and they can be moved flexibly as spatial needs change. A wide range of versatile add-ons are available.



TECHNICAL INFORMATION	Includes wheels and adjustable support legs.
MATERIAL DESCRIPTION	Plywood + chipboard frame filled with acoustical wool. Available with pine, oak and black oak veneer. Both sides upholstered with felt.
OPTIONS TO ADD	Whiteboard Marker tray Basketball hoop Ball shelf Dartboard Shelf Coat hanger Mug holder Magazine holder PLANT BOX

MEASUREMENTS W 1190 x D600 x H1320

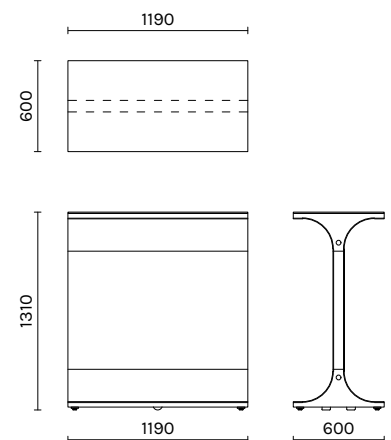



All our materials comply with M1 emission classification or similar.

FELT FOR STORY WALL: FULDA FIT FROM FILZFABRIK | STANDARD PRICE, CATEGORY 1

Composition: 30% Polyamid, 70% Polypropylen
 Static electrical propensity: Antistatic
 Classification for use: Commercial / heavy use
 Fire resistant: Yes

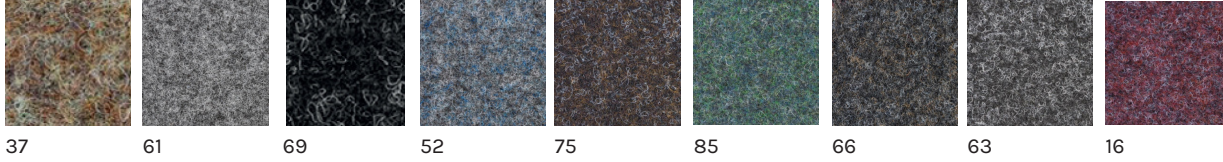

COLOR OPTIONS FOR STORY WALL FRAME

STANDARD PRICE, CATEGORY 1

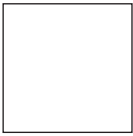

White MDF

STANDARD PRICE, CATEGORY 2

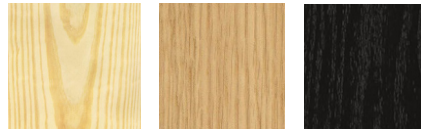

Pine

Oak

Black oak





CORNER PIECE FOR STORY WALL

Corner piece for the STORY WALL can be used to create corners and therefore, for example, rooms and nooks for teamwork and brainstorming.

TECHNICAL INFORMATION Includes strong magnets for attaching to the STORY WALL.

MATERIAL DESCRIPTION Chipboard frame.
Available with pine, oak and black oak veneer.
Both sides upholstered with felt.

MEASUREMENTS W260 x D75 x H2000 mm

Option for a corner piece for STORY WALL HIGH and STORY WALL LOW available.
Contact: sales@intoconcept.com

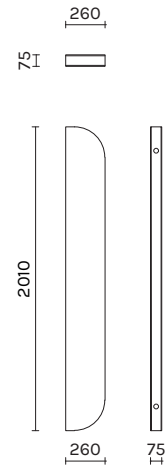

FELT FOR STORY WALL CORNER PIECE: FULDA FIT FROM FILZFABRIK | STANDARD PRICE, CATEGORY 1

Composition: 30% Polyamid, 70% Polypropylen
Static electrical propensity: Antistatic
Classification for use: Commercial / heavy use
Fire resistant: Yes



All our materials comply with M1 emission classification or similar.



37

61

69

52

75

85

66

63

16

TV BRACKET FOR STORY WALL

Turn your space divider into a stylish screen holder.
TV Bracket comes with a marker tray that has an extend cord holder.

TECHNICAL INFORMATION Holds a screen of maximum "42.

MATERIAL DESCRIPTION Steel plate painted white.



WHITEBOARD FOR STORY WALL

Convert your STORY WALL into an inspiration board with whiteboards. Multiple whiteboards can be attached side by side. There is an option for 1-4 whiteboards as add-on pieces.



TECHNICAL INFORMATION

The whiteboard is placed in a groove in the STORY WALL, where it remains firmly in place thanks to the magnets inside the space divider.

MATERIAL DESCRIPTION

Painted steel plate painted white.
Magnetic surface.

MEASUREMENTS

W1120 x H790 mm

MARKER TRAY FOR STORY WALL



Make working more efficient with a handy STORY WALL marker tray to place under the whiteboard.

TECHNICAL INFORMATION

The marker tray is placed in a groove in the STORY WALL, where it remains firmly in place thanks to the magnets inside the space divider.

MATERIAL DESCRIPTION

Steel plate painted white.

MEASUREMENTS

W1119 x D72 x H101 mm

MAGAZINE HOLDER FOR STORY WALL

Conveniently place your magazines and brochures on display in the STORY WALL magazine holder.



TECHNICAL INFORMATION

The magazine holder is placed in a groove in the STORY WALL, where it remains firmly in place thanks to the magnets inside the space divider.

MATERIAL DESCRIPTION

Steel plate painted white.

MEASUREMENTS

W215 x D72 x H305 mm

DARTBOARD FOR STORY WALL

Take a break from work and play with STORY WALL dartboard. The dartboard includes five darts.



TECHNICAL INFORMATION

The dartboard is placed in a groove in the STORY WALL, where it remains firmly in place thanks to the magnets inside the space divider. Dartboard includes five darts.

MATERIAL DESCRIPTION

Steel plate painted white.

MEASUREMENTS

W1120 x H790 mm

BASKETBALL HOOP FOR STORY WALL

Make your office or school environment more fun with STORY WALL basketball hoop. Basketball hoop comes with one small basketball.

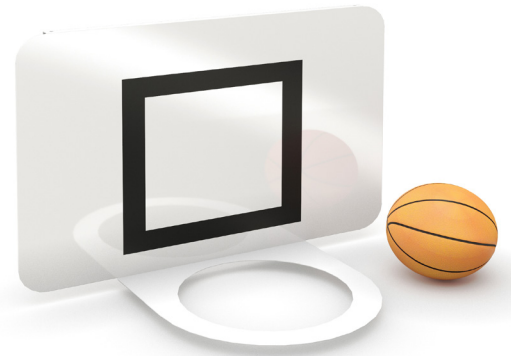

TECHNICAL INFORMATION

The basketball hoop is placed in a groove in the STORY WALL, where it remains firmly in place thanks to the magnets inside the space divider. Basketball hoop comes with one small basketball.

MATERIAL DESCRIPTION

Steel plate painted white.

MEASUREMENTS

W559 x H395 mm

BASKETBALL HOLDER FOR STORY WALL

Conveniently place your small basketball in the STORY WALL basketball holder.



TECHNICAL INFORMATION

The basketball holder is placed in a groove in the STORY WALL, where it remains firmly in place thanks to the magnets inside the space divider.

MATERIAL DESCRIPTION

Steel plate painted white.

MEASUREMENTS

W150 x H215 mm

SHORT SHELF FOR STORY WALL

Place your items and decorations on STORY WALL short shelf.



TECHNICAL INFORMATION

The shelf is placed in a groove in the STORY WALL, where it remains firmly in place thanks to the magnets inside the space divider.

MATERIAL DESCRIPTION

Steel plate painted white.

MEASUREMENTS

W560 x H240 mm

LONG SHELF FOR STORY WALL

You can use STORY WALL long shelf to display your items, plants and decorations.



TECHNICAL INFORMATION

The shelf is placed in a groove in the STORY WALL, where it remains firmly in place thanks to the magnets inside the space divider.

MATERIAL DESCRIPTION

Steel plate painted white.

MEASUREMENTS

W1118 x H241 mm

SHORT COAT HANGER FOR STORY WALL



Hang your clothes and bags on STORY WALL short coat hanger. The coat hanger has two jacket hooks.

TECHNICAL INFORMATION

The coat hanger is placed in a groove in the STORY WALL, where it remains firmly in place thanks to the magnets inside the space divider. Short coat hanger with two jacket hooks.

MATERIAL DESCRIPTION

Steel plate painted white.

MEASUREMENTS

W215 x H151 mm

LONG COAT HANGER FOR STORY WALL

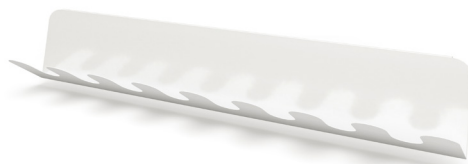

Hang your clothes and bags on STORY WALL long coat hanger. The coat hanger has nine jacket hooks.

TECHNICAL INFORMATION

The coat hanger is placed in a groove in the STORY WALL, where it remains firmly in place thanks to the magnets inside the space divider. Long coat hanger with nine jacket hooks.

MATERIAL DESCRIPTION

Steel plate painted white.

MEASUREMENTS

W1120 x H151 mm

CUP HOLDER FOR STORY WALL

Free your desk from clutter and place your cups on STORY WALL cup holder.
Small cup holder holds two cups.



TECHNICAL INFORMATION

The cup holder is placed in a groove in the STORY WALL, where it remains firmly in place thanks to the magnets inside the space divider. Small cup holder holds two cups.

MATERIAL DESCRIPTION

Steel plate painted white.

MEASUREMENTS

W215 x H149 mm. The diameter of the hole is 70 mm.

PLANT BOX FOR STORY WALL

PLANT BOX is an add-on for the STORY WALL space divider that adds greenery to the space.



TECHNICAL INFORMATION

The PLANT BOX is placed in a groove in the STORY WALL, where it remains firmly in place. Comes with plants.

MATERIAL DESCRIPTION

Pot: Finnish birch plywood, 12 mm, 9-ply. Natural, white or black.
Inner pot: 100% recycled plastic.
Connector: steel plate painted white.

STANDARDS

The manufacturer of the products made in Finland operates in accordance with internationally certified quality (ISO 9001), environmental (ISO 14001), and occupational health and safety (ISO 45001) standards.

MEASUREMENTS

W665 x D215 x H185 mm

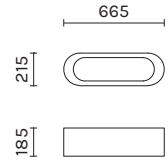

SURFACE FINISHES FOR FOR PLANT BOX

POT | STANDARD PRICE, CATEGORY 1

Standard material options



Birch

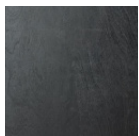

Black birch



White birch



PLANT BOX - PLANT OPTIONS

PLANT BOX is available with different plant options.



SILVER VINE



SILVER VINE AND GOLDEN MAIRE



GOLDEN POTHOS

MAINTENANCE

Silver Vine and Golden Pothos:

Prefer bright indirect light and should not be placed in direct sun. Allow the top layer of soil to dry slightly between waterings. Feed lightly during the growing season from March to October. Regular pruning helps maintain healthy and strong growth.

Golden Maire:

Thrives in bright indirect light and should be kept away from direct sunlight. Keep the soil evenly moist, but avoid letting the plant sit in water or dry out completely. Feed lightly during the growing season from March to October. Enjoys occasional misting.

WALL PANEL

The wall panels can be easily mounted to existing walls, providing a simple solution to enhance acoustics in any space. In addition to improving sound quality, they add a vibrant touch of color into the environment.

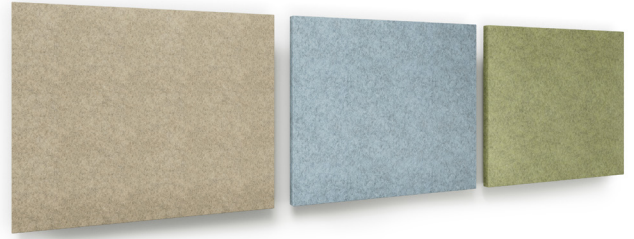

TECHNICAL INFORMATION

Easy to attach and detach with effortless fastening system.

MATERIAL DESCRIPTION

Plywood frame with acoustic wool.
Fully upholstered.

MEASUREMENTS

W1200 x D45 x H1000 mm

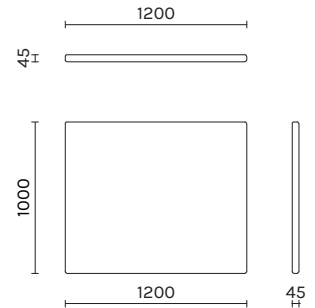

WALL PANEL FABRIC: SOUL FROM GABRIEL | STANDARD PRICE, CATEGORY 1

Composition: 100% wool
 Lightfastness: 5-7
 Rubbing fastness: 4/wet, 4-5/dry
 Sustainability: Complies with STANDARD 100 by OEKO-TEX
 Meet Möbelfakta requirements
 Cleaning: regular vacuum cleaning
 Fire resistant: Yes (S 476 Part 7, class 1 ÖNORM B 3825-B1-3800-Q1 UK)



All our materials comply with M1 emission classification or similar.



66104 67039 68131 64086 62059 61196 60182 68128 61199 60099